



**'Wadkin' Through Feed  
Four Side Straightening/  
Planing Machine and Moulder**

**Model GC**

**Instruction Manual**

---



**'Wadkin' Through Feed  
Four Side Straightening/  
Planing Machine and Moulder**

**Model GC**

M/C No.
TEST No.

**Instruction Manual**

---



---

INSTRUCTION MANUAL

WADKIN

THROUGH FEED FOUR SIDE  
STRAIGHTENING/PLANING MACHINE  
AND MOULDER

MODEL GC4 & GC4 + 1

PREFACE

Health and Safety  
Safeguarding machines

[www.wadkin.com](http://www.wadkin.com)  
[info@wadkin.com](mailto:info@wadkin.com)

---



---

## IMPORTANT

### SAFETY PROCEDURES AND CONSIDERATIONS

To ensure safe working conditions, persons operating and assisting with the operation of this machine must ensure that they read and fully understand the instructions given within this manual and have received sufficient training in the use of the machine and the safety aspects to be observed.

**Note:-** Persons under the age of 18 years must not operate the machine except during the course of training under the supervision of a trained operator.

#### A) POINTS TO NOTE BEFORE OPERATING OR ASSISTING WITH THE OPERATION OF THE MACHINE.

- 1) You have read and understand the operation and safety aspects of the machine and have been checked out by a qualified supervisor.
  - 2) The machine is supplied with full safe guarding. The machine shall not be operated unless the safe guardings are in position and are functional.
  - 3) Cutters/blades are the correct type, suitable for the machine and working conditions, rotate in the correct direction of cut, are sharp and correctly fitted.
  - 4) Correct spindle and speeds are selected for the cutter equipment and working conditions.
  - 5) Loose clothing is either removed or securely fastened back and jewellery removed.
  - 6) Adequate working space and lighting is provided.
  - 7) All dust extraction equipment is switched on, properly adjusted and working adequately.
  - 8) The machine is securely installed (refer to installation section within this manual).
  - 9) The machine should only be used for cutting wood or materials with physical and technological characteristics similar to wood, and for which the chip or particle removal process is similar.
  - 10) Only use tooling that complies with prEN 847-1. Sawblades made of High Speed Steel (HSS) MUST NOT be used.
-



**B) DURING MACHINING:-**

- 1) Wear suitable protective clothing e.g, approved eye protection, ear defenders and dust masks. Gloves shall be worn when handling tooling.
- 2) Stop the machine using the emergency stop or at the mains isolator before making adjustments, cleaning or carrying out maintenance.
- 3) Keep the floor area around the machine clean and free from wood refuse. Do not allow the floor around the machine to become slippery.
- 4) Stop the machine and report immediately to a person in authority any actual or potential malfunction or operator hazard. Do not attempt to repair or rectify the machine unless qualified or authorised to do so.
- 5) The operator must not leave the machine running whilst unattended.
- 6) Never by-pass interlocks.

**WARNING:-**

Failure to observe correct operating procedures prior to and during operation of this machine can result in severe injury.

**DO NOT** attempt to operate the machine while under the influence of anything that reduces your alertness.

## PREFACE

### IMPORTANT

IT IS OUR POLICY AND THAT OF OUR SUPPLIERS TO CONSTANTLY REVIEW THE DESIGN AND CAPACITY OF OUR PRODUCTS. WITH THIS IN MIND WE WOULD REMIND OUR CUSTOMERS THAT WHILE THE DIMENSIONS AND PERFORMANCE DATA CONTAINED HEREIN ARE CURRENT AT THE TIME OF GOING TO PRESS, IT IS POSSIBLE THAT DUE TO THE INCORPORATION OF THE LATEST DEVELOPMENTS TO ENHANCE PERFORMANCE, DIMENSIONS AND SUPPLIERS MAY VARY FROM THOSE ILLUSTRATED

[www.wadkin.com](http://www.wadkin.com)  
[info@wadkin.com](mailto:info@wadkin.com)

## HEALTH AND SAFETY

This machine is designed and constructed using the principles of safeguarding and practical guidance contained in the British Standard Codes of Practice BS5304: 1988 "Safeguard of machinery", BS6854: 1987 "Safeguard woodworking machines" and current guidance issued by the Health and Safety Executive.

The Health & Safety at Work etc Act 1974 places duties in designers, manufacturers and suppliers to ensure that:-

- (1) Articles supplied for use at work are, so far as is reasonably practicable, safe and without risks to health during setting, use, cleaning and maintenance.
- (2) Persons supplied with the articles are provided with adequate information about the use for which they are designed, and about conditions necessary to ensure that they will be safe and without risks to health.

These duties are transferred to you if you re-supply the machine by way of sale, lease, hire or hire-purchase.

Persons who install this machine for use at work have a duty under the Health and Safety at Work etc Act 1974, to ensure so far as is reasonably practicable, that nothing about the way in which it is installed makes it unsafe or a risk to health. This includes such aspects as correct assembly, electrical installation, construction of enclosures, fitting of guards and exhaust ventilation equipment. When installing the machine, consideration must be given to the provision of adequate lighting and working space.

The legal duties of designers, manufacturers, importers, suppliers, erectors and installers are explained in the free Health and Safety Executive leaflet IND(G) 1(L) 1987.

The machine is supplied complete with all necessary safeguards to enable the user to comply with the Woodworking Machines Regulations 1974. Details of correct installation and use, together with guidance on fitting and proper adjustment of guards are described in Sections 1 to 4 of this manual.

You are reminded that the Woodworking Machines Regulations place absolute legal duties on employers and employees to ensure that guards and any other safety devices are securely fitted, correctly adjusted and properly maintained.

Repairs and maintenance must only be undertaken by suitably qualified and competent technicians. Ensure that all power supplies are isolated before any maintenance work commences. Instructions for routine maintenance are given in Section 4 of this manual.

Machine operators must have received sufficient training and instruction as to the dangers arising in connection with the machine, the precautions to be observed and the requirements of the Woodworking Machines Regulations which apply, except where they work under the adequate supervision of a person who has a thorough knowledge and experience of the machine and the required safeguards.

Persons under the age of 18 years must successfully complete an approved course of training before operating this machine at work, unless participating in a course of training under adequate supervision. (N.B. This paragraph is only relevant to; circular sawing machines, any sawing machine fitted with a circular blade, any planing machine for surfacing which is not mechanically fed or any vertical spindle moulding machine.)

Before commencing work, ensure that the cutters/blades are, set to cut in the correct direction, securely fitted, sharp, and are compatible with the machine and spindle speed.

### Dust

Wood dust can be harmful to health by inhalation and skin contact and concentrations of small dust particles in the air can form an explosive mixture. These concentrations usually occur in dust extraction equipment which may be destroyed unless explosion precautions have been taken in the design and installation of the equipment.

Employees have duties under the Factories Act 1961 and the Health and Safety at Work etc Act 1974 to control wood dust in the workplace and from 1st October 1989 more specific requirements will be imposed by the Control of Substances Hazardous to Health Regulations 1988.

Employers should carry out an adequate assessment of the possible risks to health associated with wood dust to enable a valid decision to be made about the measures necessary to control the dust. It may be necessary to provide effective exhaust appliances.

Prevention or control of wood dust exposure should, so far as is reasonably practicable, be achieved by measures OTHER than the provision of personal protective equipment.

Airborne dust levels should not exceed 5 mg/cub.m

Further information and reference to practical guidance are contained in the following free leaflets available from the Health and Safety Executive:-

Wood Dust:	IND(S) 10(L) 1987
Hazards and Precautions	
Control Hardwood Dust	IND(S) 21(L) 1988

## Noise

Noise levels can vary widely from machine to machine depending on conditions of use. Persons exposed to high noise levels, even for a short time, may experience temporary partial hearing loss and continuous exposure to high levels can result in permanent hearing damage. The Woodworking Machines Regulations require employers to take reasonably practicable measures to reduce noise levels where any person is likely to be exposed to a continuous equivalent noise level of 90 dB(A) or more, over an 8 hour working day. Additionally, suitable ear protectors must be provided, maintained and worn.

An adequate assessment of likely noise exposure should be made using manufacturer's data and if necessary, a noise survey should be carried out by a competent person. It may be necessary to construct a suitable noise enclosure, in which case professional advice should be sought.

Machines identified as generating unhealthy noise levels should be appropriately marked with a warning of the need to wear hearing protection and it may be necessary to designate particular areas of the workplace as "Ear protection zones". Suitable warning signs are specified in the Safety Signs Regulations 1980.

Further information and reference are contained in the free Health and Safety Executive leaflet - Noise at Woodworking Machines IND(S) 22(L) 1988.



## SAFEGUARDING MACHINES

To comply with the Woodworking Machines Regulations 1974, operators must ensure that they fully understand the instructions given and have received sufficient training in the use of the machine and the particular safety instructions to be observed.

**NOTE:** Persons under the age of 18 years must not operate the machine except under supervision during a course of training.

### BEFORE OPERATING THE MACHINE ENSURE THAT:

All guards and fences are securely fitted and correctly adjusted in accordance with the Regulations. Cutters/blades are the correct type and rotate in correct direction of cut, are sharp and securely fastened.

Correct spindle speed is selected for the cutter equipment.

Loose clothing is either removed or fastened and jewellery removed.

Suitable jigs and push sticks are available as appropriate.

Sufficient working space is provided and that lighting is adequate.

All dust extraction equipment is switched on, properly adjusted and working efficiently.

### DURING MACHINING:

Wear suitable protective equipment, e.g. goggles, ear defenders, and dust mask.

Stop the machine before making adjustments or clearing chips from the work area.

Keep the floor area around the machine clean and free from wood refuse.

Do not allow the floor to become slippery with oil or grease.

Report immediately to a person in authority, any machine malfunction or operator hazard. Do not attempt to repair the machine unless qualified to do so.

Ensure all power sources are isolated before commencing any maintenance work.

**WARNING:** Failure to comply with the Regulations is a criminal offence and could result in legal proceedings.

**SECTION 1 GENERAL DESCRIPTION****Operating Practice**

General notes  
Machine feed systems  
Noise

**Common Operating Problems****Leading Particulars**

Principal dimensions and capacities  
Output of motors

**SECTION 2 INSTALLATION****Lifting and Transportation**

Unloading  
Moving  
Unpacking  
Cleaning

**Installation Data**

Major dimensions and weight  
Location and foundations  
Supplies and services

www.wadkin.com  
info@wadkin.com



---

**SECTION 3 OPERATING INSTRUCTIONS**

**General Information**

- Safety
- Safety devices
- Warnings
- Machine controls

**Mounting the Cutterblocks**

- General
- First bottom head
- Fence side head
- Near side head
- Top head
- Second bottom head

**Setting up the Machine**

- Set infeed table
- Check/adjust top head
- Set feed rolls/first bottom head
- Check/adjust fence side head
- Check/adjust near side head
- Check/adjust second bottom head
- Final adjustments and settings

**Faults in the Workpieces and their Causes**

- General
- Faults caused by tools
- Faults in Grinding and setting

**Cleaning the Machine**

**SECTION 4 MAINTENANCE****Scheduled Maintenance**

- Lubrication
- Vee-belt drive tensioning
- Cleaning

**Unscheduled Maintenance**

- Changing cutterblock spindle bearings
- Preparation prior to fitting bearings
- Replacing drive belts
- Removal and refit of drive pulleys
- Variable speed unit
- Cutters and tool holders
- Feed roll drives and gearboxes

**Fault Finding**

- Mechanical faults
- Elimination of Vibration
- Electrical faults

**Tables**

- Approved lubricants
- Motor/drive-belt data

**SECTION 5 ILLUSTRATED PARTS LIST**

- Bedplates fences and side guide
- First and Second Bottom heads
- Fence and Near Side head carriage assembly
- Top Head including power rise and fall
- All spindle units
- Top Head chipbreaker pressure pad and extraction hood
- Top roller pressure unit
- Variable speed drive unit
- Feed roll drives
- Feed roll belt drive - M/c 109 to 186
- Single side roller pressure unit
- Beam power rise and fall

## LIST OF ILLUSTRATIONS

**Section 1**

- Fig 1 Main view of machine  
Figs Operating practice (in text)

**Section 2**

- Fig 1 Lifting the machine  
Fig 2 Overall dimensions

**Section 3**

- Fig 1 Machine controls - general view  
Fig 2 Hand controls and adjustments  
Fig 3A First bottom head  
Fig 3B First bottom head  
Fig 4 Fence side head  
Fig 5 Near side head  
Fig 6 Top head  
Fig 7 Infeed table setting  
Fig 8A Feed rolls setting  
Fig 8B Feed rolls spacer detail  
Fig 9 Top head setting  
Fig 10 Fence side head setting  
Fig 11 Nearside head and chipbreaker  
Fig 12 Final adjustments and settings

**Section 4**

- Fig 1 Vee-belt drive tensioning  
Fig 2 Spindle unit bearing assembly  
Fig 3 Removing a Taper-Lock bush  
Fig 4 Variable speed drive unit  
Fig 5 Fitting a new friction ring  
Fig 6 Drive cone adjustment  
Fig 7 Feed roll drives and gearboxes

**Section 5**

- Fig 1 Bedplates fences and side guide  
Fig 2 First and second bottom heads  
Fig 3 Fence and Near side head carriage assembly  
Fig 4 Top head including power rise and fall  
Fig 5 All spindle units  
Fig 6 Top head chipbreaker pressure pad and hood  
Fig 7 Top roller pressure unit  
Fig 8 Variable speed drive unit  
Fig 9 Feed roll drives  
Fig 10 Feed roll belt drive  
Fig 11 Single side roller pressure unit  
Fig 12 Beam power rise and fall

## SECTION 1 GENERAL DESCRIPTION

## OPERATING PRACTICE

**General Notes on all models of Wadkin Planing and Moulding Machines**

A planing and moulding machine produces planed or moulded surfaces on all four sides of lengths of timber, both hard and softwood, at feed speeds determined by the cutter equipment and quality of surface finish required.

A series of 'ridges' (cutter marks) is created on the surface of the timber as it is moved past a rotating cutterblock (see Fig 1). The quality of surface finish is determined by the number of knife marks per 25mm (1") (the pitch of the cutter marks). The closer the pitch the better the quality of surface finish.

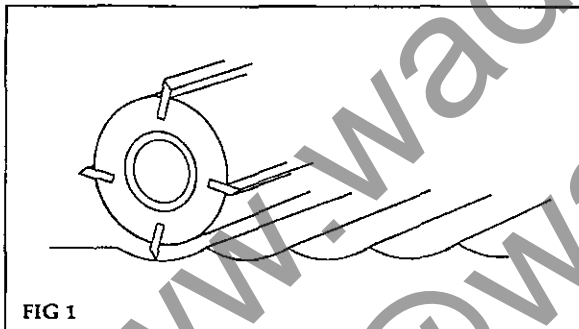

FIG 1

From experience a good quality surface finish has knife marks at a pitch of 1.5 to 2 mm. Reducing the pitch improves the surface finish but increases the wear on the cutters, increasing the pitch reduces the quality.

The number of cutter knives in a cutterblock will only be effective when all are rotating in precisely the same cutting circle. Two main factors influence this:

- a. The fit of the cutterblock on the spindle
- b. The concentricity of grinding.

The conventional method of mounting a cutterblock is to lock a plain bore block on to a plain ground spindle with a locknut. The tolerances in each component give a possible 0.05mm (0.002") clearance in the bore and thus eccentric running (see Fig 2).

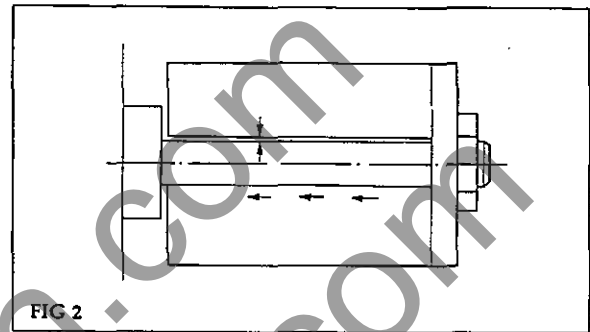

FIG 2

The Wadkin Hydrofix locking system eliminates this clearance by pressurising the bore of the cutterblock onto the spindle (see Fig 3).

Axial locking is not required and a simple safety collar is recommended to prevent the cutterblock moving axially, or rotating on the spindle, if the hydraulic pressure is not applied.

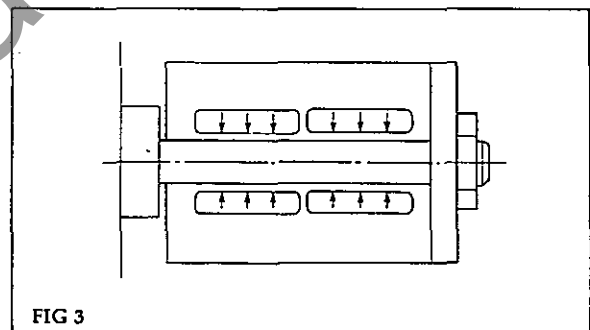
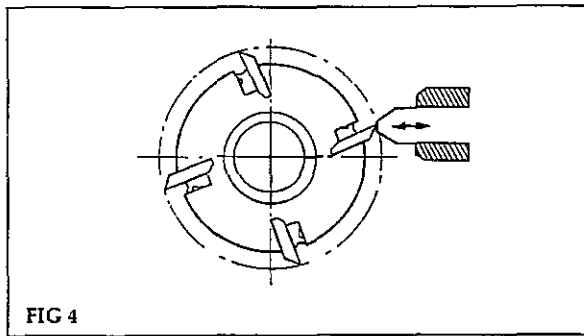

FIG 3

Because the Hydrofix locking is also used while the knives in the cutterblock are ground in the toolroom, it can be seen that the high accuracy of the grinding process is transferred directly to the planing and moulding machine. This accuracy, together with the true running of the precision spindle of the moulder, reduces the running of the knives to within 0.002 to 0.005mm of the true cutting circle. However, this minimum run-out is still such that only one knife leaves a finishing cut, no matter how many are in the block.

To ensure that all the knives in a cutterblock run in an absolutely true cutting circle, the technique of jointing is used, in which the jointing 'stone' trues all the knives while rotating at cutting speed in the planing and moulding machine (see Fig 4).



It can be seen that for a given spindle speed and quality of surface finish (pitch of knife marks), the feed speed may be increased in direct relationship to the number of knives in the cutterblock.

$$\text{Cuttermark pitch} = \frac{\text{Feedspeed in mm per min}}{\text{Block rpm} \times \text{No of Cutters}}$$

For example  $\frac{12 \times 1000}{6000 \times 1} = 2\text{m pitch}$

for a spindle running at 6000 rpm and a feed speed of 12m/min and unjointed (1 knife finishing)

Jointing a 4 knife block and increasing the feed speed to (4 × 12) ie: 48m/min gives the same resulting pitch (finish).

Jointing can be carried out on straight planing blocks — 'straight' jointing, and on profile blocks — 'plunge' jointing.

The process of jointing, which can be repeated several times, produces a heel on the knives. In the interests of quality this must not be allowed to exceed a certain width. This is approx 0.5mm on softwood and 0.7mm on hardwood (see Fig 5).

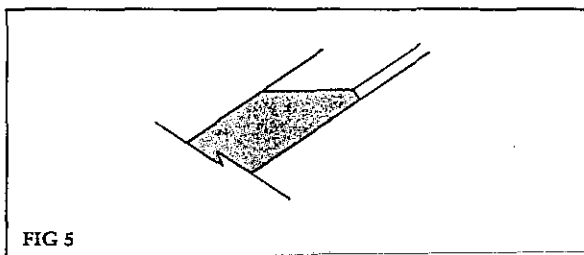

Both high speed steel and carbide knives may be jointed but require a different composition of jointing stone.

An alternative method of increasing output is to increase the spindle speed thus permitting a faster feed speed for a given quality of surface finish. 'Wadkin' can offer alternative spindle speeds up to a maximum of 15000 rpm. This highest spindle speed, achieved with very high precision, lubricated for life bearings, permits a 2½ × (250%) increase in output without jointing.

Typical surface finish pitch values for different applications are listed:

Sawmilling	1.5 to 2.5 mm
Joinery	1.5 to 2 mm
Strip moulding	1.3 to 2.0 mm
Furniture	1 to 1.5 mm

#### Machine Feed Systems

##### Push Feed (Fig 6)

This original method of feeding a planing and moulding machine is still provided, and consists of two top driven and two opposed bottom driven feed rolls at the infeed end of the machine. An idle roller and pad pressures between the cutterheads controls the timber down to the bed and across to the fence as it passes through the machine. It follows that if bowed or twisted stock is fed to the cutters, that while a perfect profile will be produced, the component will be as twisted or bowed as it entered.

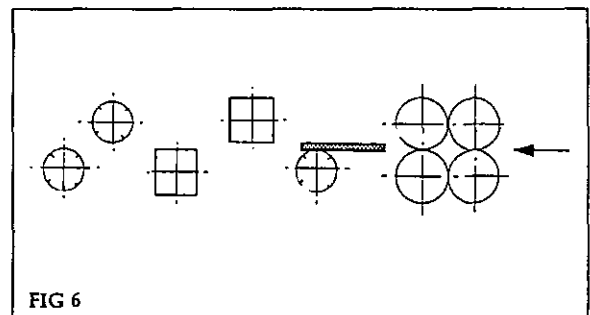

The pushfeed machine has the disadvantage that the last piece of timber is always left in the machine; traction stops as the trailing end leaves the feedworks. The last piece can only be retrieved by following with a scrap length or by reverse feeding, in which case the component is unfinished.

*Through feed (Fig. 7)*

Through feed was developed to overcome the handicap of the last piece remaining in cut, and to eliminate the heavy top and side pressures.

Drive rolls between each cutterhead feed the components through the machine.

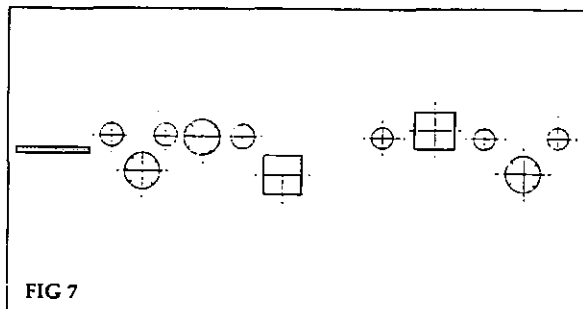

A long infeed table before the first bottom head, together with the much lighter loading on the timber, enables straightening of the component ie: the underside being straightened (surfaced) at the first bottom head, and the edge (fence side) being straightened at the first side head (see Fig 8).

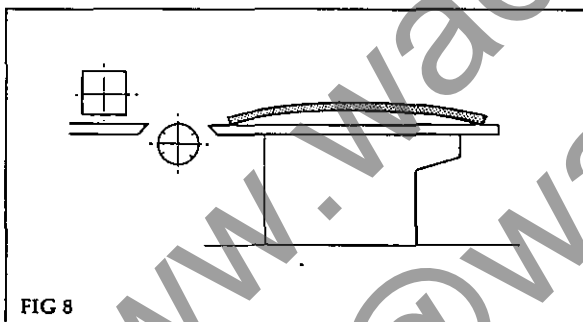

An alternative method of straightening combines underside and fence side straightening, using a single cutterblock, planing the underside in the normal way and machining a reference edge with a rebating disc on the same block (see Fig 9).

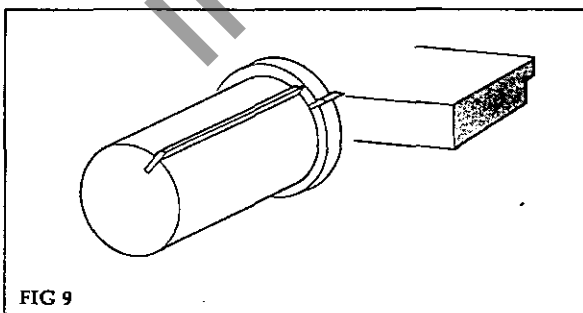

The above straightening techniques are most successful on timber which is bowed and has square ends, typical of softwood. For timber which is twisted and has out-of-square ends, typical of some hardwoods, an alternative technique is provided.

*Grooved bed straightening (Fig 10)*

In this design, grooving cutters on the first bottom head permit support in the form of rails right through the cut, thus preventing 'dipping in' of the twisted timber, or 'buckling' as out-of-square ends come into contact with each other. The grooves on the underside are subsequently machined out on a second bottom head, which is obligatory. Fitting a standard lip plate and cutterblock converts the machine to conventional use.

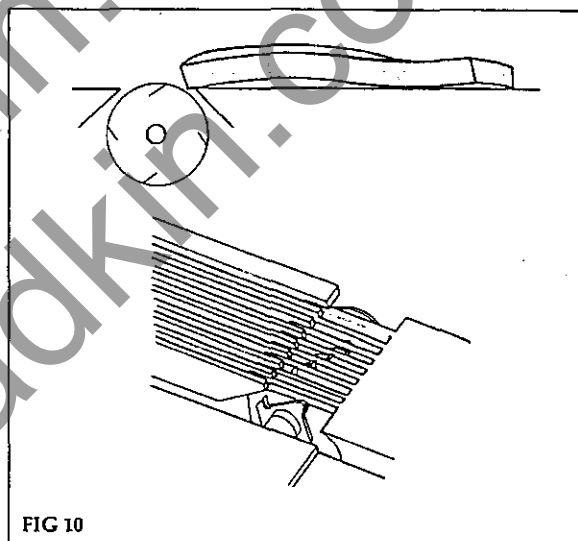

*Hopper Feeding (Fig 11)*

To enable the operator to feed timber at relatively fast feed speeds and still maintain butt up, (this may be difficult on short lengths), various types of hopper feed are available.

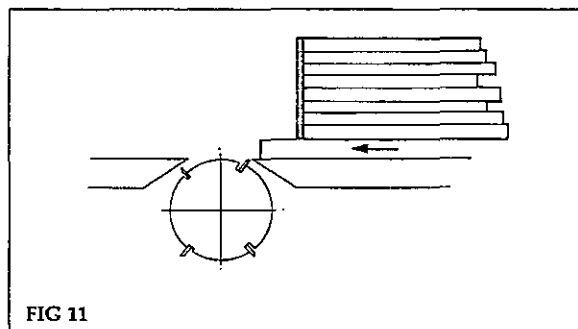



Components are stacked in a hopper at the infeed end of the machine and automatically fed one at a time from the bottom of the stack at a rate to ensure 'butt-up'. A slipping device prevents the hopper feed trying to overdrive the machine feed.

Feeding at very high feed speeds, typically on flooring, cladding etc, also presents problems to the operator, again a special feeding device. (Fast feed table, Fig 12) can be provided.

The fast feed table, in line with the machine feed, receives timber from a tilt hoist and cross chains, the driven rollers in the fast feed table and an overhead hydraulically driven nip roll ensure butt up before entry into the machine feedworks, a slipping arrangement prevents overdriving.

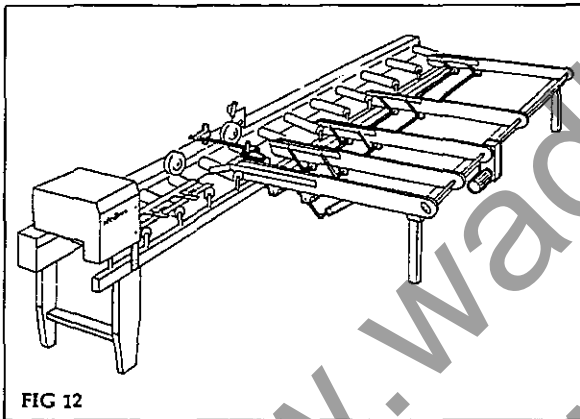

FIG 12

#### Outfeed Equipment

Generally used on high feed speed machines, this equipment can be provided at the outfeed end of 'Wadkin' moulders to transfer to another process, ie: stack, bundle, wrap, count, etc. Outfeed equipment can be provided and programmed to print on each component some identifying information. eg. Job No. Date, etc. Combinations of these facilities enable the finished components to be presented in a variety of ways at the outfeed end of the machine.

#### Extra Head Positions

Typically a planing and moulding machine has four heads to machine all four faces, these can be augmented with the addition of other heads. The most common is a second bottom head to ensure clean up on the underside. Where the amount of timber to be removed is great, or where the mould detail is complex, it

may be necessary to provide an extra bottom head, available as an option.

#### Splitting (Fig 13)

Splitting is a common operation, usually done on the last bottom head, and often requiring very large horse powers. Such a head is available and may be fitted with anti kick-back fingers to prevent ejection towards the operator. Only one saw can be fitted on the smaller machines, ie. GC.

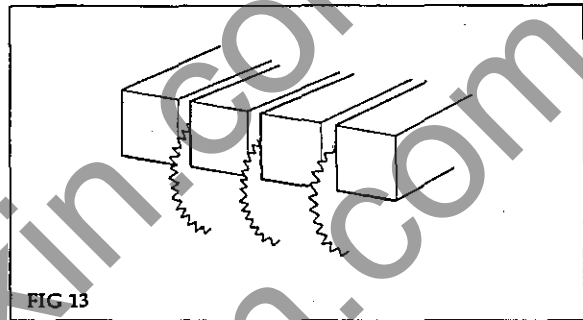

FIG 13

#### Universal Head

A universal head, either three or four position (always last head on the machine) can be provided to order, or the machine prepared to fit the head at a later date. The three position head may be used as a top head, bottom head or near side head and at any angular position in between. The four position head has the added capability of use as a fence side head.

The universal head gives greater flexibility for splitting and moulding on a conventional machine, and special pressures, chipbreakers, etc. can be provided to ensure perfect control of the workpiece.

#### Dial-a-Size Positioning (Fig 14)

On machines which are used for a large variety of small quantity batches of square dressed

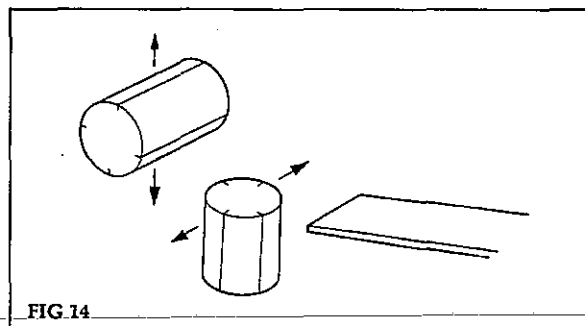

FIG 14

material, the set up time can be reduced by fitting Dial-a-size positioning.

The near side head horizontal adjustment is motorised and fitted with an encoder, the motorised vertical movement of the top head and feed is also fitted with an encoder.

A programmable memory stores the widths and thicknesses of the workpieces to be produced, and on command the two heads are repositioned to the preset dimensions. In a similar manner, where components of random width are machined (eg. Table tops, see Fig 15). The machine can be arranged to sense the width of the incoming pieces and automatically move the outside head to the required position.

Whilst being a slow operation, (butt feeding is not possible and the feed speed is slow), the facility does have great advantage to some users.

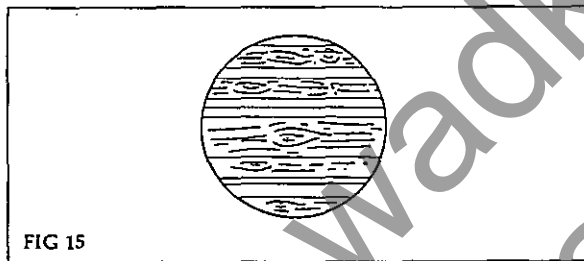

#### Feed Enhancement

The 'Wadkin' push feed and through feed systems are the result of years of experience in the planing and moulding industry, and for the great majority of work are exemplary. However, the great variety of timbers available, and the different conditions in which they are presented to the machine is acknowledged in the various options available to enhance feeding and minimise bed wear.

#### Bed Lubrication

A lubricant is introduced to the surface of the machine bed, from a manual or auto pump; this reduces friction, improves feeding capability and reduces bed wear.

An alternative; of introducing air between the timber and the bed of the machine, can be provided for those machines that do not have a second bottom head to machine off the small amount of oil introduced to the underside of

the timber, or where the material being machined must not in any circumstances be contaminated with oil.

#### Feed Rolls

The top driven feed rolls of a through feed moulder are normally spring loaded down onto the workpiece. The required amount of load can vary with the nature of the work being run, although as a general rule it must be as light as practicable, and variation in rough timber thickness will of course increase the load as the feed rolls yield more. Adjustment of the loading is done at each individual roll.

Pneumatic loading can be provided; this has a number of advantages. The loading does not vary with any variation in lift, and the amount of loading can be changed more easily, using an air regulator valve.

One regulator controls the loading to rolls before the top head, and the other regulator controls the rolls after the top head.

#### Noise



Planing and moulding machines, by virtue of the number of cutter heads and the speed of the heads, produce high noise levels, typically between 95dB and 115dB when cutting.

The woodworking machine regulations require that an operator is not to be subjected to noise levels above 90 dBA for 8 hours, some precautions are therefore required, and a safety/acoustic cover is supplied for this purpose.

It should be noted however that even with a sound enclosure, under some circumstances, because of 'break out' (at say the infeed end), the noise level at the operating positions will be above 90 dBA.

For personal safety reasons the operator should wear ear defenders.

**WARNING** Before operating the machine read the Preface and Notice to Operators in Section 3, Operating Instructions.

**COMMON OPERATING PROBLEMS**

When resolving problems, always work in a systematic logical sequence. Work from the infeed end of the machine through to the outfeed end, checking for faults in a progressive manner.

In this way faults will not be overlooked and remedial action can be taken where needed.

Set (spring loaded) top/side pad pressures with minimum amount of lift. Set side guides (not spring loaded) just up to timber ie: not clear, not trapping. When feeding wide pieces, on a through feed machine it is normally better to space feed rollers than have a solid bank, (see *Setting up the Machine*).

**FAULT Timber stops in machine****Check**

Setting of cutterblocks to table and fences.  
Amount of pressure applied to feedrolls (pneumatic or spring).  
Sharpness of cutters.  
Yield of chipbreakers and pad pressures.  
Tightness of side guides onto timber.  
Oil level of bed lubrication pump (if fitted).  
Position of feedrolls on workpiece.

**FAULT Ripples appear on surface of workpiece****Check**

Setting of cutterblocks to table or fences.  
Pressure is applied to feedrolls (pneumatic or spring)  
Sharpness of cutters.  
Chipbreakers are set correctly and have sufficient pressure to control timber.  
All locks are applied.  
All pressure pads are in contact with timber.  
Spindle speed (if two speed spindle fitted)  
Tooling is suitable for the work.

**FAULT Bumps on infeed or outfeed end of workpieces****Check**

Setting of cutterblocks to table and fences.  
Sharpness of cutters.  
Chipbreakers are set correctly and have sufficient pressure to control timber.  
All locks are applied.  
All pressure pads are in contact with timber.  
Position of side and top pressure rollers.  
Bed and fences for build up of resin or chips.

**FAULT Machine will not straighten timber****Check**

Setting of cutterblocks to table and fences (accurate setting of knife edge to table/fence is critical to obtain perfect straightening).  
Sharpness of cutters.  
Feed rollers and top/side pressures should not be used before the first bottom head.  
Is the amount of cut set at the infeed fence and table adequate for the amount of bow in the timber?  
Is the timber to be straightened a stable section?  
Is the workpiece within the length of the straightening table and fence?

**FAULT Timber runs away from fence****Check**

Position of side pressure roller before first bottom head (if fitted, and section being worked does not require straightening).  
Near side head chipbreaker is in contact with timber.  
Top idle roller pressures at side heads are parallel to fence.  
Side guides after fence sidehead are adjusted correctly.  
Mating faces of feed rolls and spacers are clean.

**Tooling**

When practicable and heads are available, rough out on one head and finish on another, or take part of a mould out on one head and part on another.

Sharp tools produce good quality work, therefore change blocks and sharpen knives at regular intervals to obtain best performance. The cutterblocks supplied with the machine are fitted with high speed steel cutter knives, unless otherwise specified. The cutter spindles should not be run at speeds above that indicated.

The following items of tooling are included as standard:

- 1 - 230mm long × 125mm diameter 2 knife cutterblock with edge reference, complete with 3mm thick HSS planning knives.
- 1 - 230mm long × 125mm diameter 2 knife cutterblock, complete with 3mm thick HSS planning knives.
- 2 - 130mm long × 125mm diameter 2 knife cutterblock, complete with 3mm thick HSS planning knives.

## LEADING PARTICULARS

### Principal Dimensions and Capacities

Maximum size of timber admitted	230mm × 130mm
Maximum size of finished work	220mm × 120mm thick
Feed speed (infinitely variable)	6.0 to 22 metres per min.
Pressure adjustment of Feed Rolls	6 bar - reduced (when fitted)
Limit switch at the extremities of the Rise and Fall Beam	
Feed Rolls	140mm diameter - 2 × 20mm + 1 × 10mm wide rolls to each position (50mm max)
Diameter of Cutter Spindles	40mm
Speed of Cutter Spindles	6000 rpm
Diameter of Cutting circles	Minimum 100mm all heads Planning: 125mm all head Moulding: 195mm (180mm on Bottom Heads)
Maximum Straightening	10mm
Maximum cut of First Bottom Head	10mm
Maximum cut of Fence Side Head	10mm
Length of Infeed Straightening Table	2 metres (when fitted)
<b>Output of Motors</b>	
Feed Motor	1.5kW (2hp)
Spindle motors	
GC4 and GC4 + 1	
First Bottom Head	5.5kW (7.5hp)
Fence Side Head	4.0kW (5.5hp)
Near Side Head	5.5kW (7.5hp)
Top Head	7.5kW (10hp)
Second Bottom Head	5.5kW (7.5hp)

NOTE: The machine will only straighten timber if fitted with an infeed straightening table as illustrated.

Fig 1 Main View of Machine shows the general layout of the GC machine.

## SECTION 2 INSTALLATION

### LIFTING AND TRANSPORTATION

#### Unloading (Fig 1)

Verify the weight of the machine (see **Installation Data**). Ensure that all lifting equipment used is capable of lifting this weight as a minimum.

Position slings of suitable lifting capacity on the machine (see Fig). The slings must be positioned forward of the beam and be suitably blocked away from the machine body to avoid damage to components or the beam. Ensure the slings are secure before lifting.

**THE MACHINE IS DELIVERED WITH THE LARGE SAFETY COVER REMOVED, THIS MUST BE REFITTED BEFORE OPERATING ANY DRIVE OR CUTTER.**

#### Moving

In the process of moving, avoid jolting or vibrating the machine. If the ground is flat the machine can be positioned on wooden plinths and moved by rollers instead of lifting.

**IMPORTANT:** When lifting, the machine has a tendency to tilt backwards (towards the electric motors and the motor mounting brackets). Allowance should be made for this in positioning.

#### Unpacking

Undo the packing and make sure that damage has not occurred during transit; undo the case of accessories and ascertain that the machine is complete with all fittings.

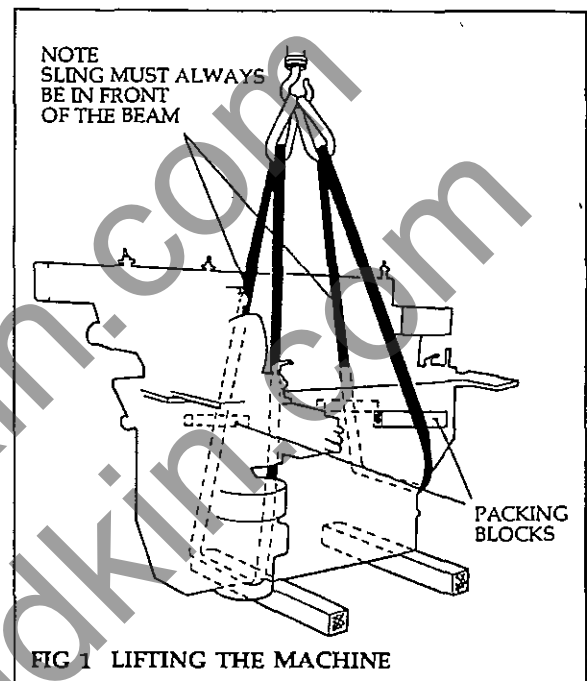

#### Cleaning

Before levelling the machine, carefully remove the anti-rust material particularly from the bright parts.

Clean the machine with paraffin or diesel and a soft rag. Do not use a substitute - it may precipitate an explosion.



## INSTALLATION DATA

### Major Dimensions and Weight

#### Overall Dimensions and Weights:

	GC4 (short table)	GC4 (long table)
Length:	2067mm	3425mm
Width:	1500mm	1500mm
Height:	825mm	825mm
Weight:	1760kg	1800kg

The addition of a second bottom head (GC4 + 1) will increase the above by 150mm in length and 200kg in weight (Fig 2).

### Location and Foundations

To obtain the best results from the 'Wadkin' woodworking machine it is important that the floor on which the machine is to stand has been prepared and is dry. Level the machine from the middle of the bed between the adjustable screw supports by the use of a spirit level. Place the steel plates supplied with the machine under the adjustable levelling screws.

#### Suggested levelling aids:

Straightedge 2 metres long  
 Feelers (thickness gauges), 0.50, 0.10, 0.15 and 0.2mm  
 Engineer's spirit level

#### Levelling longitudinally

Place the spirit level on the table and moving the level lengthwise check any variation. Adjust machine level by use of the adjustment screws in the feet of the machine. Deviation should not be more than 0.2 mm.

The straightening table (ie: table before the First Bottom Head), should be in line with the table after the First Bottom Head. Maximum tolerance is 0.1mm in 1600mm.

#### Levelling transversely

Place the spirit level across the table at right angles to the fence and repeat this action at intervals of 800mm. Total variation at each position should not exceed 0.1mm.

### The foundations

The size of the foundations depends upon the specific machine model, format of the heads and disposition of the exhaust outlets and will be provided for individual machines.

If the floor consists of 100mm-150mm (4 to 6 inches) solid concrete, no special foundation is necessary. M12 'HILTI' type holding down bolts (not supplied with the machine) can be used to secure the machine to the floor.

**NOTE: THE MACHINE MUST BE BOLTED DOWN BEFORE USE**

See Foundation Plan for details of floor area required.

### Supplies and Services

#### Electrical Supply

The customer is responsible for an adequate electrical supply. Details of power requirements are provided with the machine.

The machine is delivered with its complete electrical equipment ready for connection.

The electrical connection and schematic diagram are found in the electrical control cubicle of the machine. All that is required is to connect the power supply to the disconnect (Isolator) switch at the electrical control cubicle or panel.

### POINTS TO NOTE WHEN CONNECTING THE POWER SUPPLY

Check the voltage, phase and frequency correspond with those on the machine nameplate details.

Check the main fuses are of the correct capacity in accordance with the machine nameplate details.

Connect the incoming supply leads to the appropriate terminals.

Check all connections are sound and that equipment is earthed.

Check the spindle rotation is correct. When looking from the front of the machine the feed rolls should rotate in a clockwise direction. To reverse the rotation on any drive, reverse any two of the line lead connections at the incoming supply.

**IMPORTANT: ANY ELECTRICAL MODIFICATIONS SHOULD BE CARRIED OUT BY A COMPETANT ELECTRICIAN.**

*Pneumatic pressure equipment (where fitted).*

Where the machine is equipped with pneumatic pressure operated feedrolls, the number of connections are shown on the pneumatic circuit diagram and foundation plan. To make the system operative connect up the air pipes and fittings to a suitable air supply.

The size of the air inlet connection is 1/4in. BSP female.

The size of the air pipe is 8mm O.D. x 5mm I.D.

Pressure required is 6 bar (approx. 90 psi), see **Operating Instructions** for feedroll pressures.

The air consumption is approximately 200 cu.dm/hr (7cu.feet/hr).

*Exhaust (Dust Extraction) Connections*

The size of the connections are given on the Foundation and Dust Extraction Plan.

The part of the air extraction pipe fitted to the exhaust hood should be flexible and detachable. The length of the flexible part is dependant on the way the pipe is used and the adjustment required on the work spindle. As a guide use a flexible pipe one metre long for the lower and fence side spindles and two metres for the top and near side spindles.

The flow of air to the exhaust hoods should be approximately 25 to 30 metres per second.

*Volume of Air Required*

GC4 (four spindles)	75 cub. metres/min. (2700 cu.ft/min)
GC4 + 1 (5 spindles)	100 cub. metres/min. (3500 cu.ft/min)

The total volume of air required for the Dust Extraction is directly related to the total number of spindles and will be confirmed on supply of equipment.

*Schematic Diagram for Electrical Services*

The electrical wiring and schematic diagram will be in the electrical control cubicle of the machine.

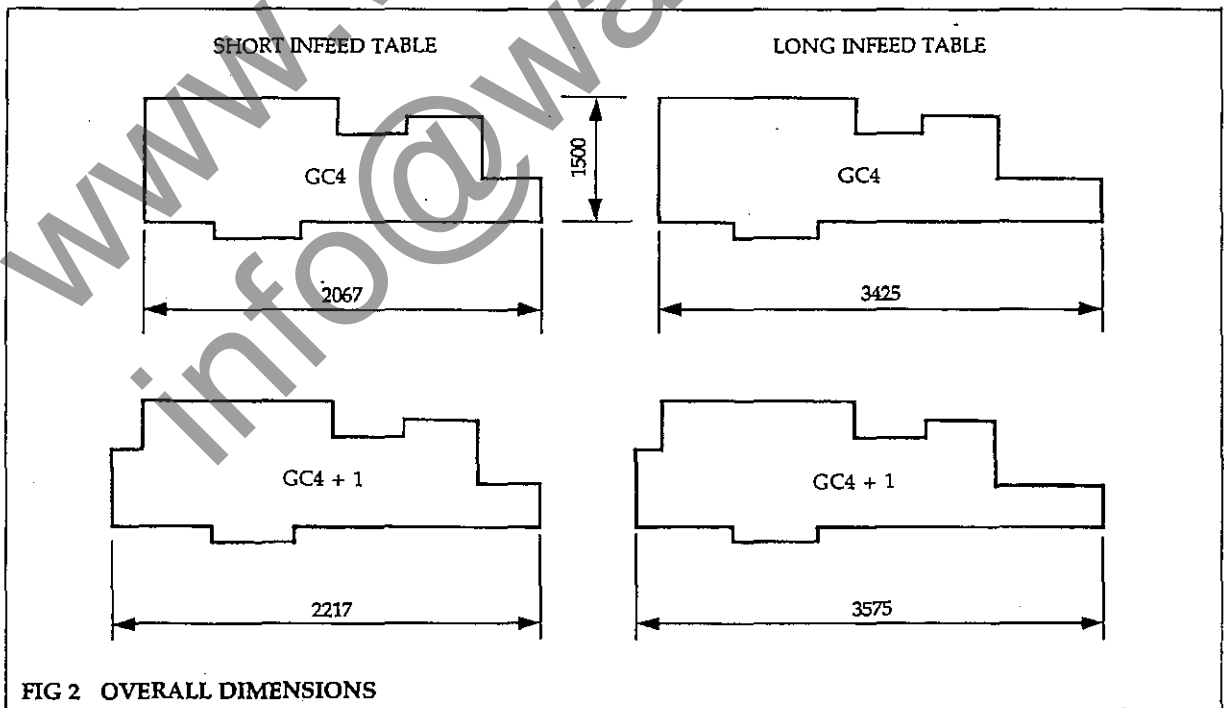



## SECTION 3 OPERATING INSTRUCTIONS

### GENERAL INFORMATION

#### Safety

The safe operation of woodworking machinery requires constant alertness and close attention to the work in hand.

**Read this instruction manual, the Preface, and the Safety Notes carefully before operating the machine.**

Blunt cutters often contribute to accidents. An efficient machinist knows when sharpening is necessary, but if there is reluctance to spend time on grinding and resetting, the cutters may run beyond their efficient limits and instead of cutting efficiently and smoothly they will tend to chop and snatch at the workpiece. This not only increases the risk of accidents but also lowers the quality of work.

Customers are strongly advised at all times to use high tensile cutterblock bolts which should be tensioned by means of a torque spanner. When choosing cutterblocks ensure they are suitable for the minimum cutting speed of the machine.

It is recommended that personnel involved with the machine are acquainted with the Woodworking Machines Regulations 1974 and also Booklet No. 41 'Safety in the use of woodworking machines', issued by the Department of Employment and available from Her Majesty's Stationery Office. Also BSI Code of Practice 'Safeguarding Woodworking Machines' Part 1 BS 6854.

#### Safety Devices

The safety covers and dust hoods must be closed during the time the machine is running. Cover the non-used part of the cutterblocks with the guards provided.

Only remove the feed roller guard when changing rollers and with spindles switched off at the control panel.

Spindles which are run in two directions (ie:

Universal Head), should be fitted with a locking collar to prevent unforeseen unlocking on mode changeover.

Do not work spindles if the spindle nuts or intermediate collars are not securely tightened.

Only remove the cover of the drive belt housing when changing or retensioning belts. The drive spindle must be stationary before making any adjustments.

#### WARNINGS

##### Notice to Operators

Read and follow the guidelines given in **Safeguarding Machines** and **Safety Notes** which are repeated on the bed of the machine.

##### Before operating the machine

Ensure that all guards and fences are securely fitted and correctly adjusted. Guards and other safety devices are NOT to be removed while the machine is in operation. They are there for YOUR SAFETY.

Ensure cutters/blades are the correct type and rotate in correct direction of cut, are sharp and securely fastened.

Correct spindle speed and feed is selected for the cutter equipment.

Remove or fasten loose clothing; confine long hair and remove jewellery, etc.

Ensure suitable jigs and push sticks are available as appropriate.

Ensure sufficient working space is provided and that lighting is adequate.

Switch on all dust extraction equipment, ensure it is working correctly.



### During machining

Wear suitable protective equipment, e.g. goggles, ear defenders, dust mask.

Stop the machine before making adjustments or cleaning woodchips from the work area.

Keep the floor area around the machine clean and free from wood refuse.

Do not allow the floor to become slippery with oil or grease.

Report any machine malfunction or operator hazard to a person in authority immediately. Do not attempt to repair the machine unless qualified to do so.

Ensure all power sources are isolated before commencing any maintenance work.

Comply with the Woodworking Machines regulations. Failure to do so could result in legal proceedings.

### Machine Controls (Fig 1)

Before starting the machine, operators should familiarise themselves with the various controls and their usage (Fig 1).

Check direction of spindle rotation, ensuring that the spindles rotate freely. Check each spindle motor separately.

Check the infeed table raise and lower operation.

The machine has continuous feedworks. When started, timber stock will be fed to the cutter heads until the pass is completed or the machine is stopped. The feed speed is variable and can be adjusted by a handwheel at the drive gearbox to give throughput speeds between 6 and 20 metres a minute. **Only adjust the variable speed drive while in motion.**

The feed rolls have serrated teeth up to the top cutter head after which they are rubber covered. The serrated rolls need to be adjusted to 3mm lower than the thinnest workpiece; the rubber covered rolls should be adjusted to 1mm lower than the workpiece.

The height of the feed roll adjustment is indicated by the graduated scale on the vertical pillar adjacent to the feed table. Adjustment of the feed rolls is made by pressing the pushbuttons marked:

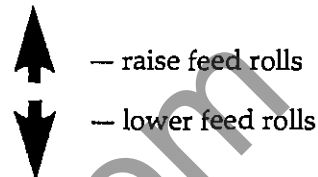

The pushbuttons are positioned on the Electrical Control Panel located at the infeed end of the machine and also at the control station located at the outfeed end of the machine.

The adjustment for height of the rubber covered (plain) rolls may be made independently to suit the finished workpiece.

The panel mounted control station at the infeed end of the machine contains the following features:

- START-STOP Pushbutton; with indicator light, for each spindle.
- START-STOP Feed Pushbutton; with indicator light.
- FORWARD-REVERSE (Inch) Feed Pushbuttons.
- RAISE-LOWER Pushbuttons; for beam adjustment.
- MASTER STOP (Emergency) Button.

OPERATING INSTRUCTIONS  
MOUNTING THE CUTTERBLOCKS

General

To change cutterblocks, remove dust hood covers and unscrew the cutterblock nut from the spindle with the combination spanner supplied with the machine.

- (1) Place the combination spanner on the hexagon of the spindle and on the two flat faces of the cutterblock locknut.
- (2) Hold the spanner (top) securing the spindle firmly in position and unscrew the cutterblock locknut with the bottom spanner.

**NOTE:** Spindles have right or left-hand threads as follows:

Bottom Horizontal spindle — left-hand thread  
Near Side Vertical spindle — left-hand thread

Top Horizontal spindle — right-hand thread  
Fence Side Vertical spindle — right-hand thread

DO NOT use any form of percussion tool on the cutter heads, damage to spindle bearings can result. DO NOT use a box-spanner or an extension spanner.

- (3) Carefully clean spindles, cutterblocks, sleeves and any intermediate spacers before refitting.
- (4) After fitting, turn the spindle slowly to ensure the cutterblock is free. Close the cover.

**WARNING:** Ensure that all spindles are pulled up tight before running the machine.

- (5) Operate the spindle for a short period to ensure it rotates freely and without vibration.

**CAUTION:** On vertical spindles take care not to allow the cutterblock to fall onto the spindle shoulder while fitting. This can cause damage and subsequent vibration.

**NOTE:** Figure 2 is included to show the hand controls used to make adjustments to the machine setting. In general Figure 2 will be referred to in-text to locate the respective controls at each machine position.

First Bottom Head (Fig 3A, Fig 3B)

- (1) Remove guard for access, remove existing cutterblock as follows:
  - a. Release cutterblock (1) using the combination spanner provided on the spindle hexagon (2) and the two flat faces of the cutterblock locknut (3).
  - b. Withdraw cutterblock from spindle.

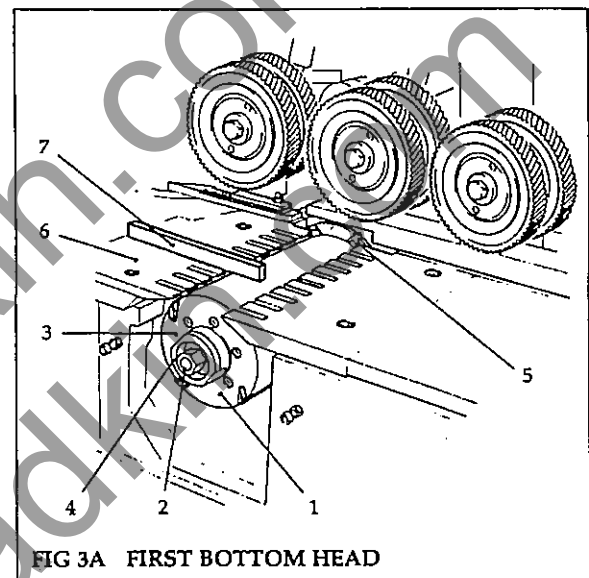

- (2) Check that the spindle (4), flange (5) and the flange end of the replacement cutterblock are clean.
- (3) Slide the new cutterblock (1) onto the spindle (4) and tighten using the combination spanner provided.

**NOTE:** Do not use excess force.

- (4) Ensure the outfeed table (6) is clean.
- (5) Place a straightedge (7) on the outfeed table projecting over the bottom horizontal cutterblock (1). The cutter blades should just touch the underside of the straightedge. If necessary, reset the cutter height as follows; (Fig 2)
  - a. Release locking handle (4) and adjust the cutterblock height by rotating the hand-screw (5) clockwise to raise the spindle, or anti-clockwise to lower.
  - b. Refasten the locking handle (4).

- (6) Place the straightedge (7) against the outfeed fence guide (8) and check that the edge reference cutter flange (9) is in line with the fence (ie; just touching the straightedge).

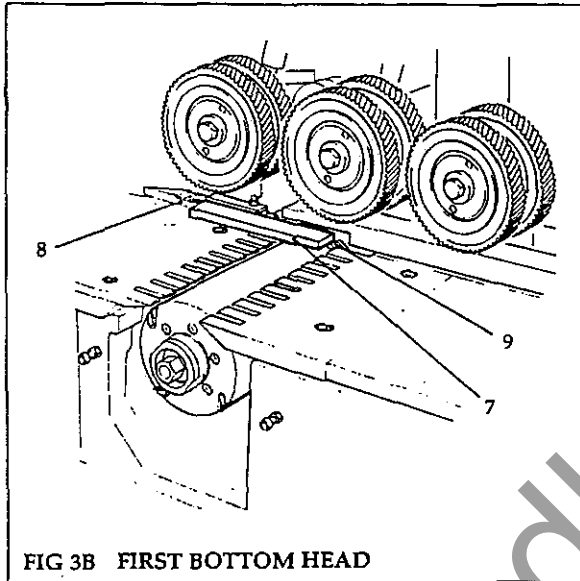

FIG 3B FIRST BOTTOM HEAD

If necessary, adjust the cutterblock laterally as follows; (Fig 2)

- a. Release the hexagon nut on the bottom head vertical slide casting at the rear of the machine and rotate the spindle adjuster (19) as required.
- b. Retighten the hexagon nut on the casing.

#### Fence Side Head (Fig 4).

- (1) Ensure that the machine bed is clean.
- (2) Set the fence (1) with a straightedge (2) against the fence and cutters (3) in a similar manner to that used for the **First Bottom Head**.

If necessary, adjust the spindle laterally as follows; (Fig 2)

- a. Release the locking handle (17).
- b. Rotate the handscrew (14) clockwise to advance the spindle or anticlockwise to retract the spindle.
- c. Refasten the locking handle (17).

**NOTE:** Maximum lateral adjustment is 65mm.

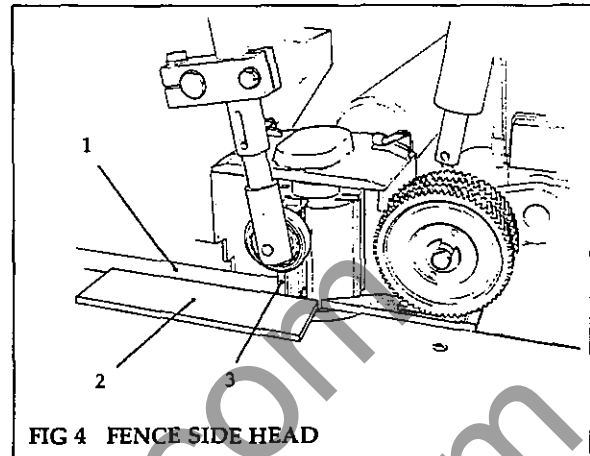

FIG 4 FENCE SIDE HEAD

If necessary, set the height of the cutterblock; (Fig 2)

- a. Release the locknut. Adjust the cutter height by rotating the hexagon adjuster (12) anticlockwise to lower the spindle or clockwise to raise the spindle. Tighten the locknut.

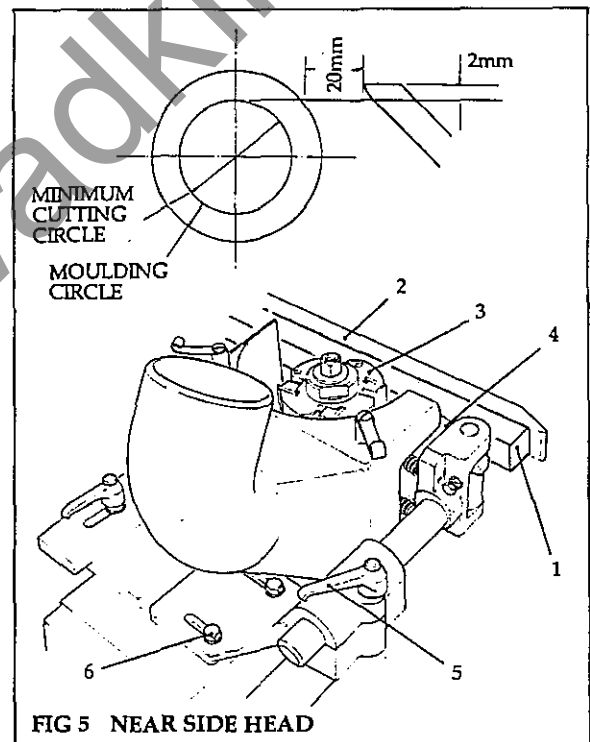

FIG 5 NEAR SIDE HEAD

#### Near Side Head (Fig 5)

- (1) Ensure that the machine bed is clean.
- (2) Check the digital readout, using a datum block (1) of known width inserted between the fence guide (2) and cutter (3). The cut-

terblades should just touch the near side of the datum block. If necessary, re-position as follows; (Fig 2)

- a. Release locking handle (13).
- b. Rotate handscrew (15) clockwise to advance the spindle or anticlockwise to retract the spindle.
- c. Refasten locking handle (13).
- d. Reset digital readout, where fitted, to the known dimension.

(3) Set the chipbreaker (4) as follows:

- a. Remove the cover of the dusthood.
- b. Release the locking handle (5)
- c. Adjust the chipbreaker (4) so that it clears the smallest cutting circle by approximately 2mm (Fig 5).
- d. Refasten the locking handle (5).
- e. Unscrew the bolts (6) and adjust the chipbreaker (4) to suit the cutterblock diameter so that it clears the cutterblock by 20mm (Fig 5).
- f. Retighten the bolts (6).

**Top Head (Fig 6)**

- (1) Ensure that the machine bed is clean.
- (2) Using the same datum block (1) as in Near Side Head, set the cutter (2) as follows; (Fig 2)
  - a. Release locking handle (7).
  - b. Rotate handscrew (6) clockwise to lower the spindle or anticlockwise to raise the spindle.
  - c. Refasten locking handle (7).
  - d. Reset digital readout, where fitted, to the known dimension.

(3) Adjust the spindle laterally as required, as follows:

- a. Release the locking handle (7) and turn the handscrew (8) clockwise to advance the spindle or anticlockwise to retract the spindle.
- b. Refasten the locking handle (7).

To use the powered vertical adjustment: release the locking handle (7), engage handle (9) and hold until clutch is engaged. If the clutch does not readily engage, operate the handscrew (6) by turning slightly (to right or left) until engagement is made.

To raise or lower spindle, press the ap-

propriate button at the control stations located at either end of the machine.

**NOTE:** The powered vertical adjustment only works in conjunction with the powered height adjustment to the feedrolls. After positioning the spindle, lift the hand lever (9) to disengage the automatic vertical adjustment. Finally, if necessary, adjust manually with handscrew (6). Refasten the locking handle (7).

(4) If necessary, change position of chipbreaker shoe (3) to maintain leading edge as close to cut as possible - 20mm.

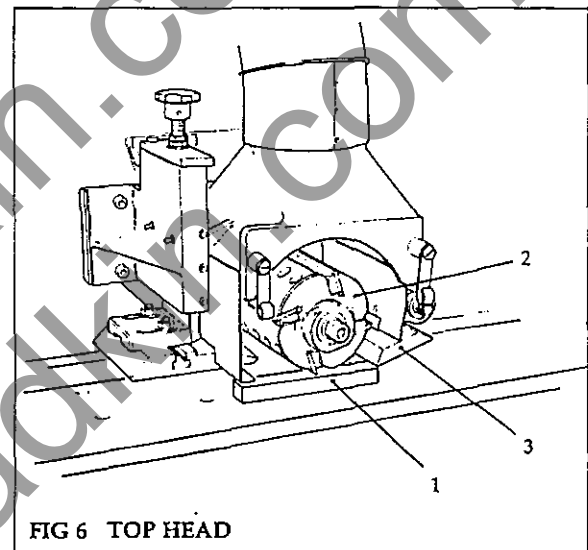

**Second Bottom Head (No Fig) – when fitted**

- (1) Ensure the machine bed is clean.
- (2) Using a straightedge (1) as in setting up the First Bottom Head, set the cutter height by adjusting cutterblock (2). The blades of the cutter should just touch the underside of the straightedge, (see Fig 3A).

To reset cutter height; (Fig 2)

- a. Release locking handle (11), rotate handscrew (10) clockwise to raise the spindle, or anti-clockwise to lower.
- b. Refasten locking handle (11).

To adjust the cutterblock laterally: use hexagon screw (18) to advance or retract the spindle.

**NOTE:** The fence is set at the same time as Fence Side Head (see Figs 4 and 10). Also, there is no edge reference cutter.

## SETTING UP THE MACHINE

### Set Infeed Table (Fig 7)

- (1) To set the height of the infeed table (1), turn the handscrew (2) with the ratchet handle provided. Set the height required from direct reading on the graduated scale (3) by moving handle to right or left as required. The maximum adjustment available is 10mm.
- (2) Set the fence (4) adjustment with handle (5) after releasing clamps (6). Refasten clamps (6) after adjustment. Set the amount of cut required by direct reading on the scale (7).
- (3) The adjustable guard (8) must be set to within 5mm of the maximum timber size. Slacken starwheel (9), set guard (8) and retighten starwheel.
- (4) Set side roller (10) to suit width of workpiece. (Not fitted on long straightening table).

### Set Feed Rolls (Fig 8A, Fig 8B)

First Bottom Head described; others are similar.

- (1) Set the feed rolls (1) to suit width and thickness of timber, ie: width of rolls to be as width of timber;

**NOTE** To achieve maximum traction on wide timber, it may be advisable to space rolls apart (Fig 8B), rather than having a solid bank of feed rolls.

Use the Control Station pushbuttons (Fig 1 Machine Controls) to set the thickness.

If necessary, change the rolls as follows:

- a. Slacken centre screw (2), using a 10mm hexagon spanner.
- b. Remove 'C' washer (3), add or remove rolls, or spacers (4), to suit width of stock (Fig 8B), ensuring that each roll drive pin engages with its mating part.
- c. Refit 'C' washer (3) and retighten centre screw (2).

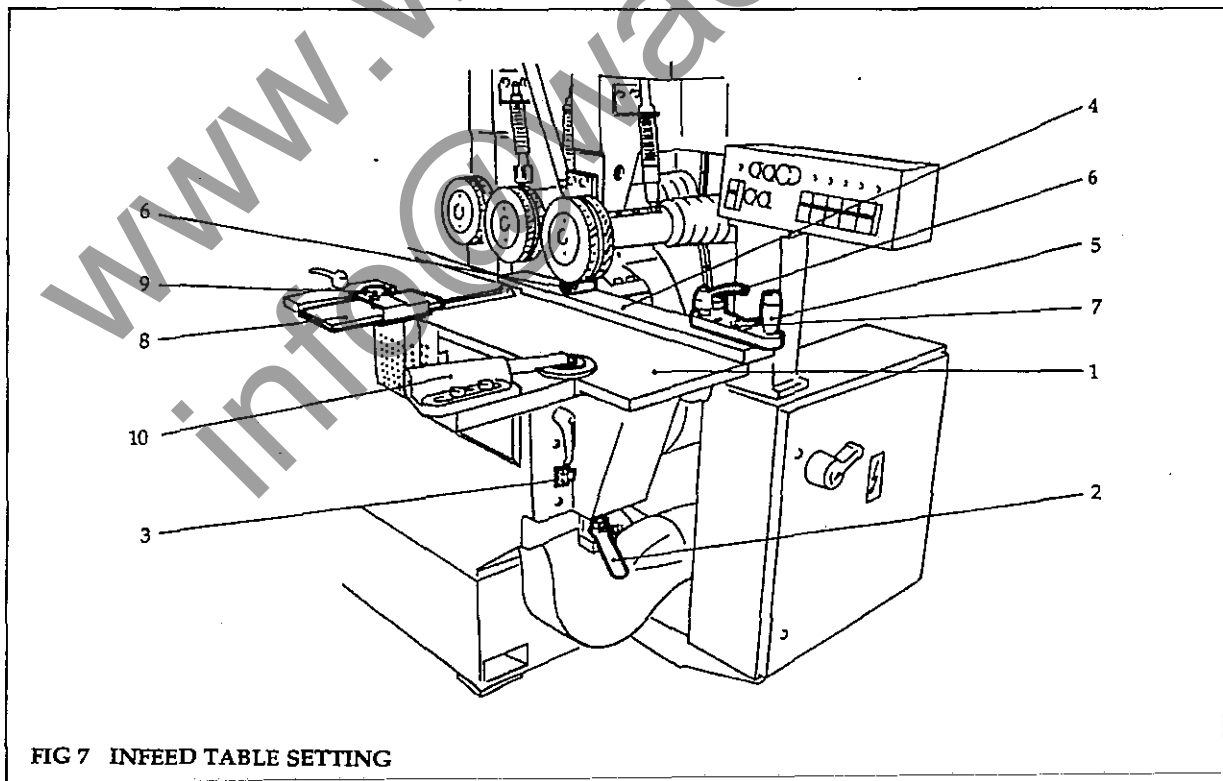

FIG 7 INFEEED TABLE SETTING

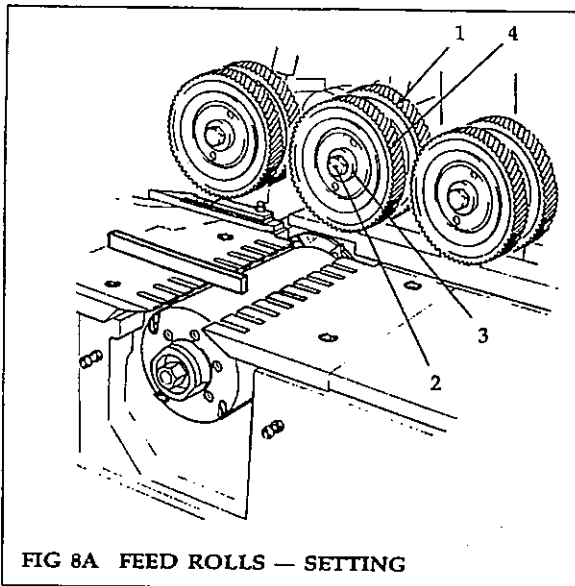

FIG 8A FEED ROLLS — SETTING

- (2) Set feed roll height 3mm lower than thinnest workpiece. Set outfeed rolls 1mm lower.
- (3) When set up, inch timber through the machine up to the top head cutter and switch off.

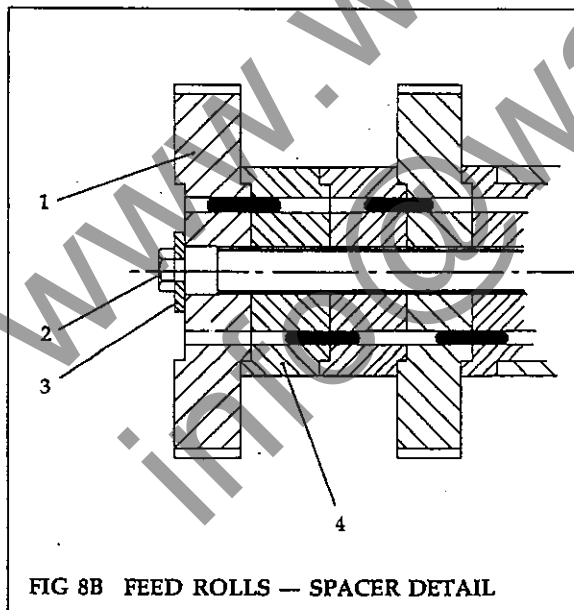

FIG 8B FEED ROLLS — SPACER DETAIL

**Check/Adjust at Top Head (Fig 9)**

- (1) Inch timber through spindle and stop prior to side heads.
- (2) If necessary, reset pressure pad after top head as follows:
  - a. Loosen the two screws (1) then slide pad (2) laterally.
  - b. Retighten screws.
- (3) Adjust pad pressure to timber thickness using starwheel (3).
- (4) Restart and feed timber through machine. Check chipbreaker settings.

**NOTE:** The chipbreaker setting is identical to that described for Near Side Head (Fig 11), except for location of adjustment and locking features, which are shown on Fig 9.

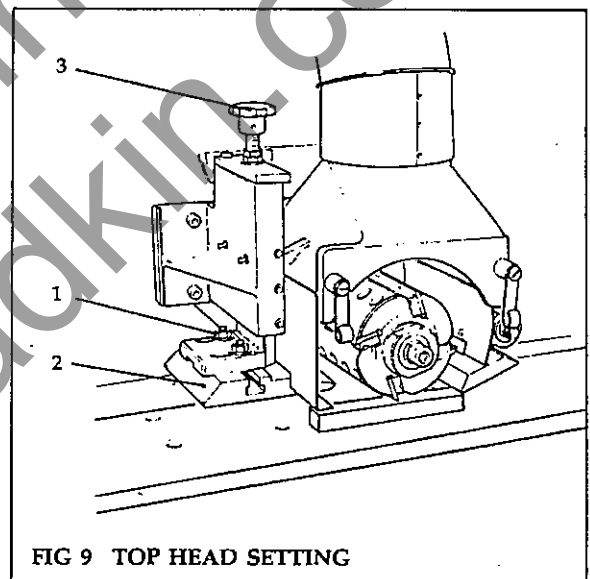

FIG 9 TOP HEAD SETTING

**Check/Adjust at Fence Side Head (Fig 10)**

- (1) Adjust the top roller pressure to the timber as follows:
  - a. Adjust the top roller by loosening screw (1) for lateral adjustment and screw (2) above the roller for height adjustment. Retighten screws.
- (2) Apply tension to the roller by adjusting the knurled head screw (3).
- (3) Set fence after Fence Side Head to line up with cutter knives, (see Fig 4).

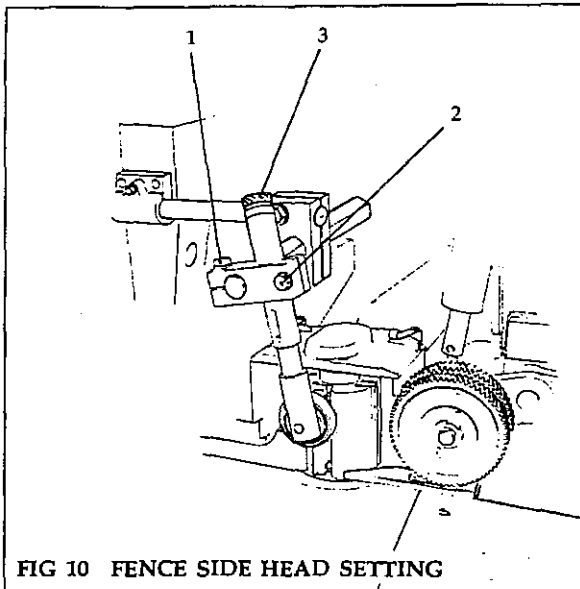

FIG 10 FENCE SIDE HEAD SETTING

**Check/Adjust at Near Side Head (Fig 11)**

- (1) Check the setting of the chipbreaker (1) adjacent to the near side head. Reset if necessary, using locking handle (2) to release slide bar (3). Retighten locking handle (2).

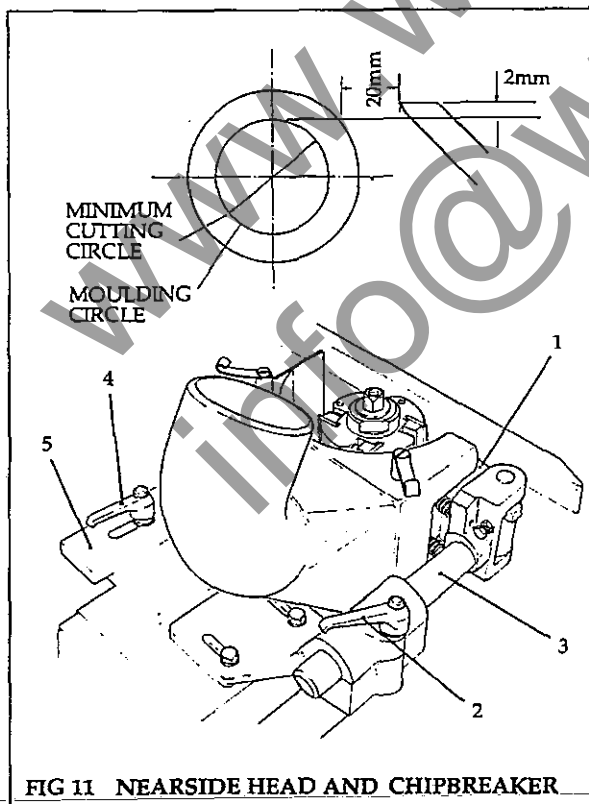

FIG 11 NEARSIDE HEAD AND CHIPBREAKER

- (2) Inch timber through machine, check machine cut.
- (3) Release locking handle (4), set side guide (5) after near side head to the timber width as machined. Refasten locking handle (4).

**Check/Adjust at Second Bottom Head (No Fig)**

- (1) Inch timber through all spindles and stop with timber over second bottom head. Switch off machine.
- (2) Set outfeed rolls height to suit timber (see Fig 12).

**Final Adjustments and Settings (Fig 12)**

- (1) Check infeed (serrated) feed rolls (1) for height setting.
- (2) Check the plain feed rolls (2) suit the new dimension of the timber workpiece.
- (3) Pass a test piece through the machine and check the dimensions and profile.
- (4) When fitted with pneumatic loading; set the air pressure on feed rolls (1) and (2) using the air supply regulators (3) and associated gauges.

**NOTE:** The first regulator and gauge is for the rolls (1) up to the top head, this should be set to a lower pressure than the regulator for the plain rolls (2).

The following pressures are recommended:

- a. steel rolls 3 bar (1 bar = 14.5 psi.)
  - b. rubber covered 4 bar
- (5) On the standard machine; set the spring pressure on feed rolls manually, using the hand adjuster screws on the spring tensioners (4).
    - a. To increase spring pressure, turn the knurled screw on the top of the spring tensioner in a clockwise direction. To decrease spring pressure, turn the screw anti-clockwise.
    - b. If the screw is turned through a distance of 5mm, pressure on roller is approximately 250N (25kg). If the screw is turned through a maximum distance of 16mm, pressure on roller is approximately 500 N (50kg).



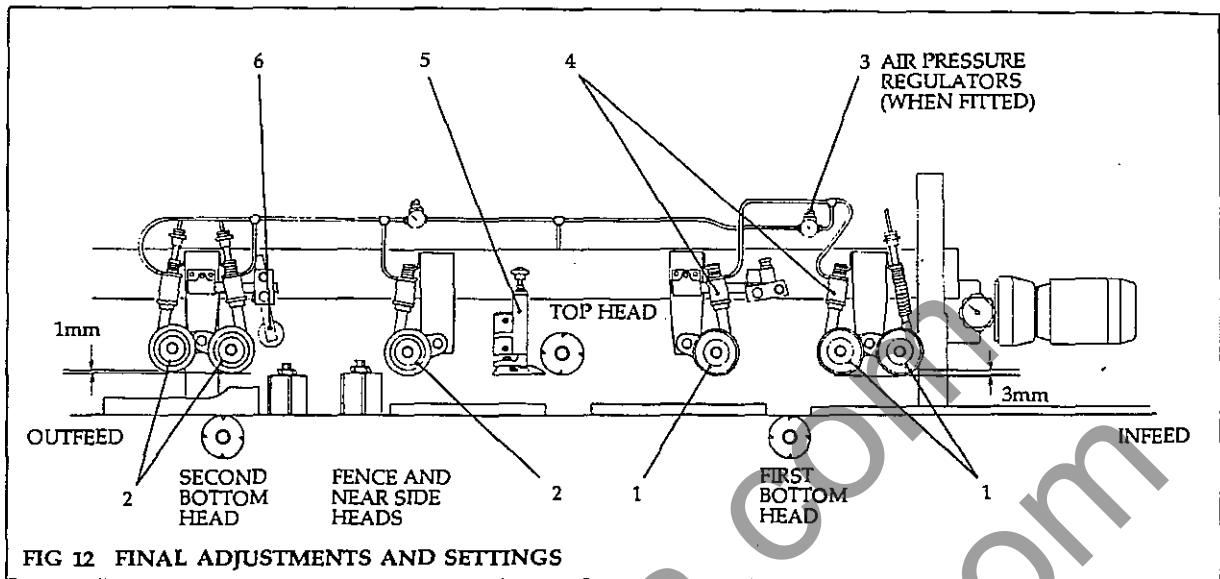

- (6) Check pressure pad adjustment (5) after top head. Raise or lower by use of the star-wheel.
- (7) Check the top pressure rollers (6) are in contact with the workpiece to maintain this in contact with the table.
- (8) Set the machine feed speed by rotation of the handwheel on the speed indicator dial with the machine running.

**NOTE: DO NOT adjust with machine feed stationary.**



## FAULTS IN THE WORKPIECES AND THEIR CAUSES

### General

**FAULT** — Blips at the leading end of the underside of the timber.

**Cause** — The cutterblock is too low in relation to the outfeed bedplate.

**Remedy** — Adjust the cutterblock correctly.

**FAULT** — Scars on the trailing end of the underside of the timber.

**Cause** — The cutterblock is too high in relation to the outfeed bedplate.

**Remedy** — Adjust the cutterblock correctly.

**FAULT** — The trailing end of the top face of the timber shows blips.

**Cause** — Pad and roller pressures are incorrectly adjusted.

**Remedy** — Adjust the pad pressures correctly

outfeed bedplate, or are badly ground.

**Remedy** — Adjust, or sharpen the cutters carefully

**FAULT** — Burn marks on the stock.

**Cause** — Cutters are blunt and need regrinding.

**Remedy** — Regrind cutters.

### Faults in Grinding and Setting

**FAULT** — Nicks in the edges of the cutters especially carbide.

**Cause** — Generally caused by removing too much metal when regrinding. This results in undue stresses and subsequent cracking and breaking away of the cutting edge when machining.

**Remedy** — Take greater care when regrinding cutters.

**FAULT** — Vibrating heads

**Cause** — Cutterblocks have been set up incorrectly. Reset.

### Faults Caused by Tools

**FAULT** — Out of square stock after planing.

**Cause** — The cutters are not parallel to the

## CLEANING THE MACHINE.

Machines are designed to need a minimum of maintenance. However, it is recommended that the machine be cleaned thoroughly once a week. This is essential when working on hardwood such as Sipo (Utile) or similar.

If cleaning with compressed air, take care not to direct the jet onto the spindle and moving shaft, bearing housings, etc. Clean the spindles and remove all remains of resin and grease. Do the same with the cutterblock collars and

machine tables (bedplates) and lightly lubricate.

Check that all machine parts slide easily at friction points. Lubricate as indicated in the lubricating instructions (see **Maintenance**).

Adjust the variable speed drive unit through the full range once a week to avoid the feed drive mechanism jamming.

## SECTION 4 MAINTENANCE

### SCHEDULED MAINTENANCE

Scheduled maintenance consists of regularly maintaining the machine in a good operating condition, capable of safely producing good quality trouble free work, with the minimum of downtime.

This includes tasks such as daily/weekly cleaning and lubrication which can and should be performed by the operator. Tasks carried out at longer intervals will require more specialised knowledge and tools to perform.

#### Lubrication

Much attention has been given to keeping lubrication and maintenance to a minimum. In consequence, 'sealed for life' bearings and 'Oilite' bushes have been used. The cutter-block spindles have been fitted with permanently lubricated bearings; these should only require replacement of lubricant if the spindle bearings are replaced. However, there are exceptions as follows:

Electric motors, where 'sealed for life' bearings have not been fitted, are provided with grease nipples. These should be greased at *monthly* intervals with Wadkin L6 grease.

There is no requirement for periodic lubrication of the feed rolls motor driven variable speed unit.

#### Weekly

Grease the machine slideways and the various traverse screws with Wadkin Grade L6 grease (see *Approved Lubricants*).

A hand operated lubricating pump is fitted to provide oil feed lubrication to the machine bed. The hand lever should be operated to deliver the required amount of oil to the bed. A tap is fitted to the pump to control the oil flow rate to a preset amount.

The oil reservoir holds 1 litre (1.76 pints) of oil. Replenish with Wadkin Grade L4 oil (see *Approved Lubricants*) as needed.

#### Monthly/3 Monthly

Grease machine drive spindles and drive

motor shafts, where fitted with grease nipples, using Wadkin Grade L6 grease unless otherwise stated. Do not overfill bearing housings.

Generally, machine drive spindles will be lubricated *monthly*.

#### Vee-Belt Drive Tensioning (Fig 1)

Check drive belts at regular intervals (as indicated below). If the need arises retension. Insufficient tension causes slipping and premature belt wear. Too much tension causes bearing wear. Tension as indicated in *Checking/Adjustment*.

Observe the operation of the machine when first put into service. After approximately one hours effective use, check and retension belts to take up initial belt stretch.

In general, Vee-belts will require adjustment at intervals to take up any slack due to use. *Three-monthly* intervals are recommended as an initial guide for the feedworks drive.

It is important to check the condition and tension of the cutterspindle drive belts at more frequent intervals, depending on conditions of use, if problems relating to quality of finish are to be avoided. *Monthly* intervals are recommended initially.

Checking/Adjustment is carried out as follows:

- (1) Remove the drive cover.
- (2) Check belt tension. The belt should be capable of being depressed approximately 1½ to 2 cm by application of average thumb pressure (see Fig. 1).
- (3) To adjust: fit spanner (1) provided, to adjusting screw (2), located at motor support bracket and turn in an anticlockwise direction to tension the belt drive (see Fig. 1).

**NOTE:** Do not overtension belts.

- (4) Refit drive cover.

There may be occasions where the tensioning arrangement does not follow that described. However, all belt drive adjustment follows the



same general principle; this involves moving the drive pulley centres or motor platform, thus taking up any slack in the belt drive. The method used will normally be self evident. Retighten any securing features fitted.

If one or more of the vee-belts becomes faulty it will be necessary to replace as a complete set. (see **Replacing Drive Belts**). It is impossible to obtain a correctly tensioned drive, with all belts taking an equal share of the load, by mixing old and new, or different belts.

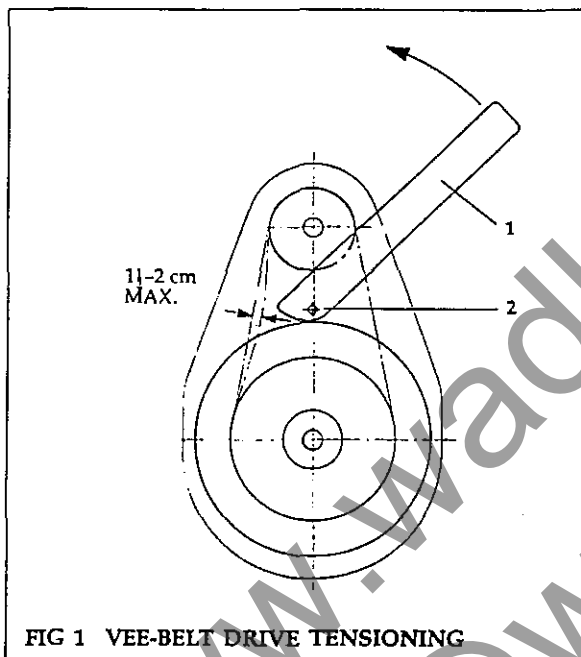

### Cleaning

Woodworking machines are designed to need a minimum of maintenance. However, a certain level of maintenance, especially cleaning and lubrication, will pay dividends in quality of work.

It is recommended that the machine be cleaned thoroughly once a week, especially when working on hardwood or highly resinous material, to prevent choking of ventilator airways and build up of deposits on working parts.

Clean all spindles regularly and remove all remains of resin and grease. Do the same with cutterblock collars and machine tables. Check that all machine parts slide, or rotate freely. Lightly lubricate as directed, do not overlubricate.

If cleaning with compressed air, take care not to direct the jet onto the spindle bearing housings, moving shafts, etc. to avoid forcing dust and debris into bearings and housings.

## UNSCHEDULED MAINTENANCE

Unscheduled maintenance consists of replacing or correcting items which are worn, damaged, or are otherwise unserviceable. Generally items which are defective will be replaced.

These tasks require specialised knowledge and tools to perform. Following this type of maintenance, the machine will need to be set up prior to return to work.

All unscheduled tasks — such as changing bearings, should be performed by competent personnel.

### Changing Cutterblock Spindle Bearings (Fig 2)

The bearings (5) have been fitted to the cutterblock spindles (6) in an orthodox manner. At the non-drive end of the spindle a liquid engineering adhesive ('Loctite' grade 241) has been applied to the internal thread diameter of the bearing nut (4).

**NOTE:** This nut can be right or left-hand thread, dependant upon spindle rotation and tightens against the direction of rotation.

To dis-assemble parts joined by 'Loctite' adhesive use normal tools and methods. If the holding force of the 'Loctite' joint is too great then apply gentle heat and break the bond while the parts are still hot. The bonding adhesive may be left as a powder and must be removed before applying further adhesive.

### Preparation Prior to Fitting Bearings

Before fitting a new bearing, the protective lubricant must be meticulously removed with petroleum spirit, triethanolamine, or other volatile solvent.

In order to prevent the moving parts from being damaged by drying out due to over cleaning, add a small amount of the bearing lubricant to the cleaning agent at the second bath. The film of grease which remains after the solvent has evaporated will provide protection for the bearing until charged with lubricant.

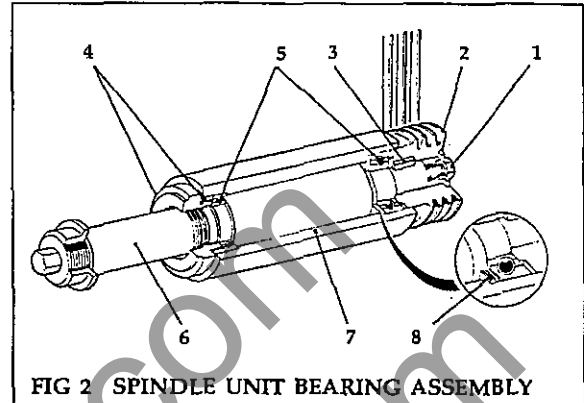

FIG 2 SPINDLE UNIT BEARING ASSEMBLY

The new bearings should be charged with 'Kluber' lubricant, type 'Isoflex' NBU 15. It is important that the correct amount of grease is applied, preferably using the formula:

$$G \text{ (weight in grams)} = d \times B \times 0.01$$

where;  $d$  = bore of bearing in mm  
 $B$  = width in mm

This is approximately sufficient to fill one third of the bearing volume.

*To remove the bearings:*

- (1) Remove pulley assembly from spindle by unscrewing the M12 hexagon screw (1). Withdraw pulley (2) and remove parallel key (3) from spindle.
- (2) Remove bearing nuts (4). Remove existing bearings (5), using a bearing puller on the bearing rings. Take care not to damage the spindle or housing.
- (3) After Preparation; fit new bearings (5) to spindle (6) and housing (7), include spring discs (8) as previously fitted. Use only sufficient pressure to fit bearings, applying pressure to the inner ring only. Ensure that bearing ring fits up to location shoulder on the spindle.
- (4) Reassemble spindle unit, lubricate bearing (see Preparation). Fit bearing nuts (4). Tighten nuts until assembly is secure. Do not over tighten.
- (5) Check that spindle assembly runs freely and without end float.



- (6) Refit parallel key (3), pulley and M12 hexagon securing screw. Tighten screw to spindle until the assembly is secure.

### Replacing Drive Belts

Drive belts must be replaced as a set to obtain correct drive performance. Before access can be gained to any drive belt it will be necessary to remove the guard covers.

#### To Replace a Drive Belt:

- (1) Relieve tension on the drive by reducing drive centres. This can be done by either:
  - a. Releasing the fixing bolts on the motor support bracket and sliding the motor forward, or
  - b. Slackening off the motor tensioner bolt, or bolts.
- (2) Remove old drive belts. Fit a new set of belts, same size, type and reference (see Motor Drive Belt Data).
- (3) Retension the new belt set (see Vee-Belt Drive Tensioning — Scheduled Maintenance), reversing step (1) a. or b., as applicable to drive motor attachment. Secure fixing bolts.

It may at times be necessary to remove a drive pulley. The motor shaft pulleys are fitted with Taper-Lock bushes (see Fig.3), cutterblock spindles are fitted with parallel keys.

### Removal and Refit of Drive Pulleys (Fig 3)

#### To remove a Taper-Lock bush pulley:

- (1) Slacken off all screws (1) several turns using a hexagonal key. Remove one or two screws according to number of jacking holes (2).
- (2) Insert screws in jacking holes after oiling thread and point of grub screws, or thread and head of cap screws, as applicable.
- (3) Tighten screws (1) alternately until bush (3) is loosened in pulley hub and assembly is free on shaft.
- (4) Remove pulley assembly from shaft.

#### To refit a Taper-Lock bush pulley:

- (1) Ensure that mating taper surfaces are completely clean and free from oil or dirt. Insert bush in hub and line up screw holes.
- (2) Oil thread and point of grub screws, or thread and head of cap screws. Place screws (1) loosely in threaded holes in hub of pulley.
- (3) Clean shaft, fit hub and bush to the shaft as a unit. Locate in position. On fitting; the bush will nip the shaft first, then hub will be drawn onto bush.

**NOTE:** It is necessary to axially align drive and driven pulleys.

- (4) Using a hexagon key, alternately tighten screws (1), until all screws are pulled up

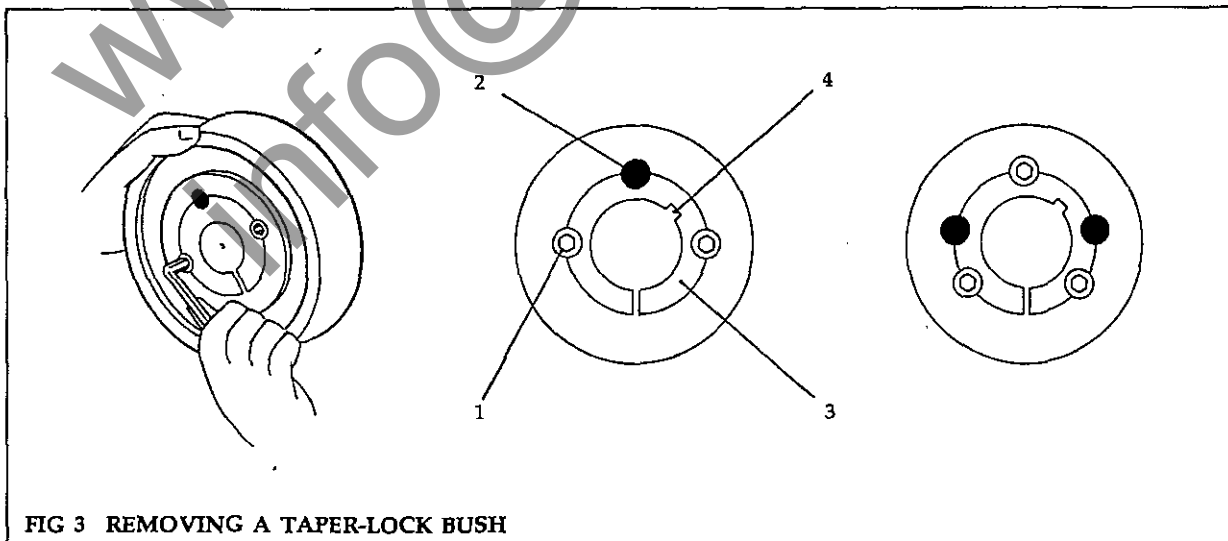

FIG 3 REMOVING A TAPER-LOCK BUSH

securely. Use a short length of pipe on key to increase leverage.

- (5) After the bush (3) has been tightened onto the shaft, fit the parallel key (4). The key is side fitting with top clearance.
- (6) After the drive has been running under load for a short time, stop and check tightness of screws. Tighten if needed.
- (7) Fill empty screw holes with grease to exclude dirt.

#### Variable Speed Unit (Fig 4)

The variable speed unit incorporated in the feed roll drive is virtually maintenance free. However, certain items may require attention at intervals.

There are two drive arrangements possible; both employ a Stober drive unit for speed variation. The only difference is in the method of power take-off to the shafts. Machines up to No 192 excluding 147, 148, 172 and 173 have the unit fitted with a belt transmitting the drive to the gearboxes. On machines 147, 148, 172, 173 and 193 onward the unit is located in line with the gearboxes.

The method of fitting a new drive belt to the unit for the early model arrangement is similar to the method described in *Drive Pulleys, Fig 3* except that a toothed belt is fitted. The drive operates on fixed centres and no adjustment is required. It may be necessary to remove both pulleys to remove the belt.

The drive parts are shown in the *Illustrated Parts List*.

If the speed drive alters on its own (speed drops); release the locking screw/handle on the speed control handwheel, reset the speed and retighten to lock the speed control setting.

If the drive slips; the friction ring in the unit is either oily, or worn, and will require cleaning or replacement, (see Fig 5).

Attachment of motor to drive unit: (Fig 4)

- (1) Remove cover on item (2) after removing capscrews (2a).
- (2) Rotate friction cone (5) into position illustrated.
- (3) Loosen coupling screw (10) in clamp ring

(11) approximately two turns, using a hexagon key. Do not remove, clamp ring remains located by screw (12).

- (4) Lightly grease motor shaft and fit into hub of friction cone (5). DO NOT use force.
- (5) Secure motor to slide with screws (1). Do not tighten screw (10) yet.

**NOTE:** Before retightening the coupling screw, rotate the motor shaft about 20 turns, either by hand (remove the fan cover and turn the fan), or connect the motor to the power supply. This is important to avoid any axial stress in the drive.

- (6) Tighten the clamping screw (10) securely in position.
- (7) Refit cover (2) with screws (2a).

**NOTE:** To facilitate mounting, the motor slide can be adjusted up or down by the handwheel and speed control shaft. Loosen or tighten brake screw/locking handle screw/locking handle if necessary.

*To remove motor:*

- (1) Follow the reverse procedure of motor attachment.

**NOTE:** Early drive units have friction cone support bearings (not illustrated). On later units the motor is attached directly to and centres the friction drive cone, the cone is located by the motor shaft on assembly.

- (2) Remove the drive motor from the unit by removing the four set screws (1) attaching the motor to the unit mounting slide (2).

*To clean/replace the friction ring: (Figs 4, 5)*

- (1) Remove the four setscrews (4) from the motor side casing, separate the two sections (3) and (9). Check the friction ring (6) for oiling or wear.
- (2) If oiled up; degrease the cone (5) and friction ring (6) surfaces with degreasing fluid. Clean with soft paper tissue to remove all traces of oil.
- (3) If the friction ring (6) is worn down to the screw heads or its metal mounting flange (7), it must be replaced.
- (4) If oil is passing along the shaft, the oil seal

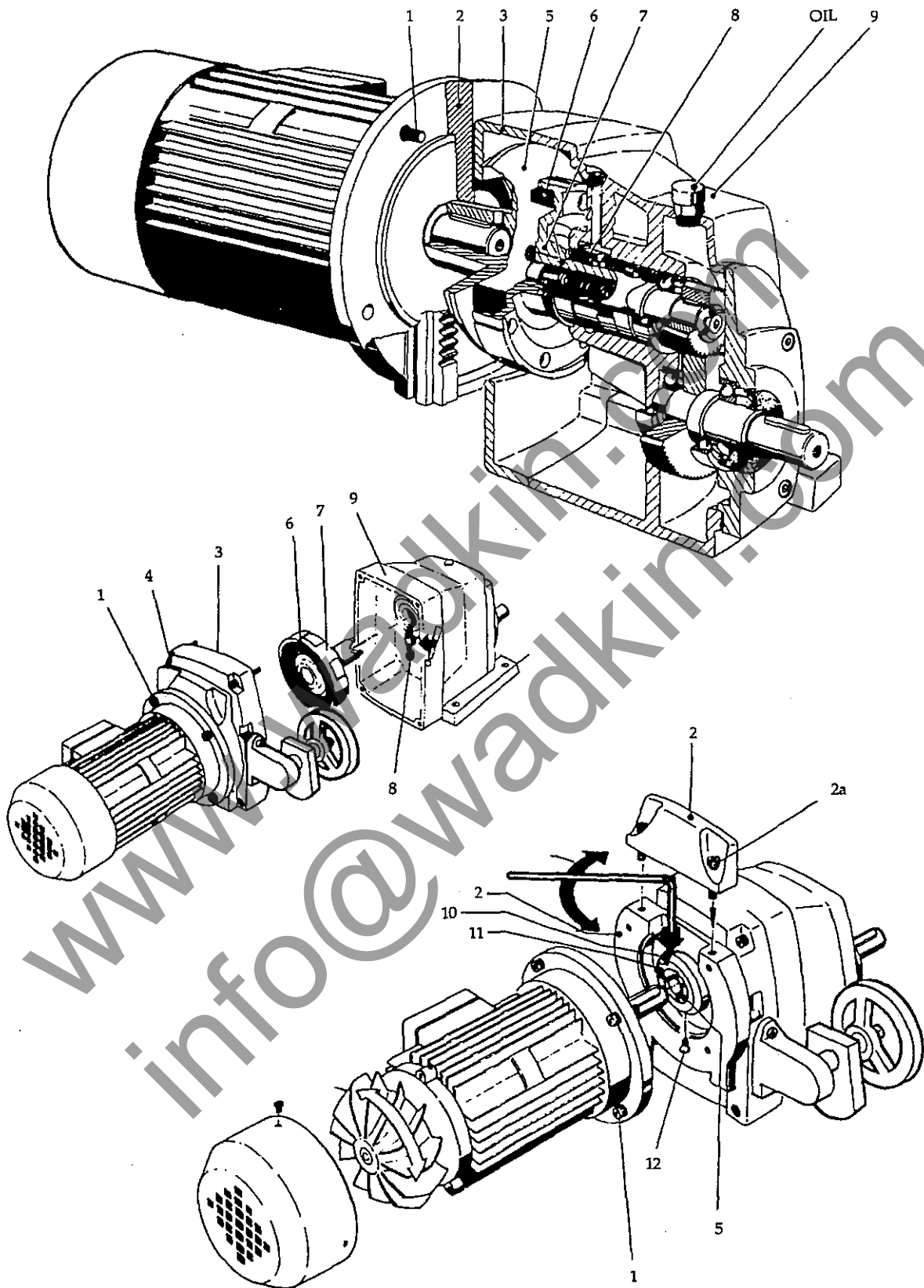

FIG 4 VARIABLE SPEED UNIT



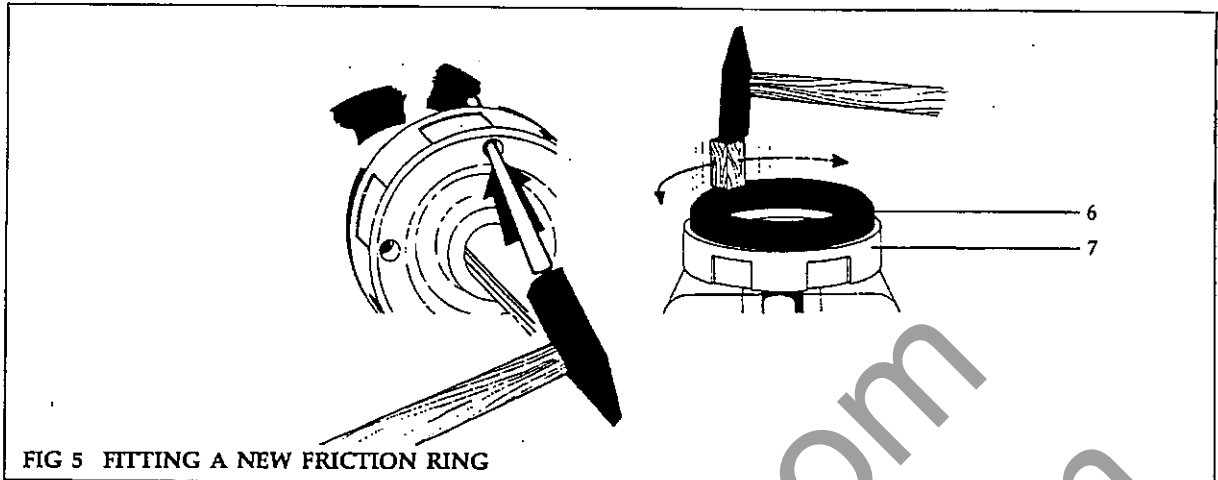

FIG 5 FITTING A NEW FRICTION RING

(8) must be replaced.

Obtain replacement item/s from Wadkin Service Dept. quoting Reference in the Illustrated Parts List for this component.

(5) Refit friction ring into unit (fitting instructions are supplied with a new ring). (see Fig 5).

**CAUTION:** To prevent damage to clutch and bearings use a suitable puller. DO NOT hammer into position.

(6) Reassemble unit drive elements and casing, ensuring that the friction ring is centred on the cone (see Note in Motor Attachment and Cone Adjustment).

(7) Secure unit casing elements with the setscrews (4) removed on disassembly.

(8) If removed on disassembly: Refit motor to drive mounting slide (2) on the unit using the four setscrews (1).

(9) Top up gearbox lubricant (Wadkin Ref.) to sightglass level. The sightglass is on the right side viewed from the infeed end.

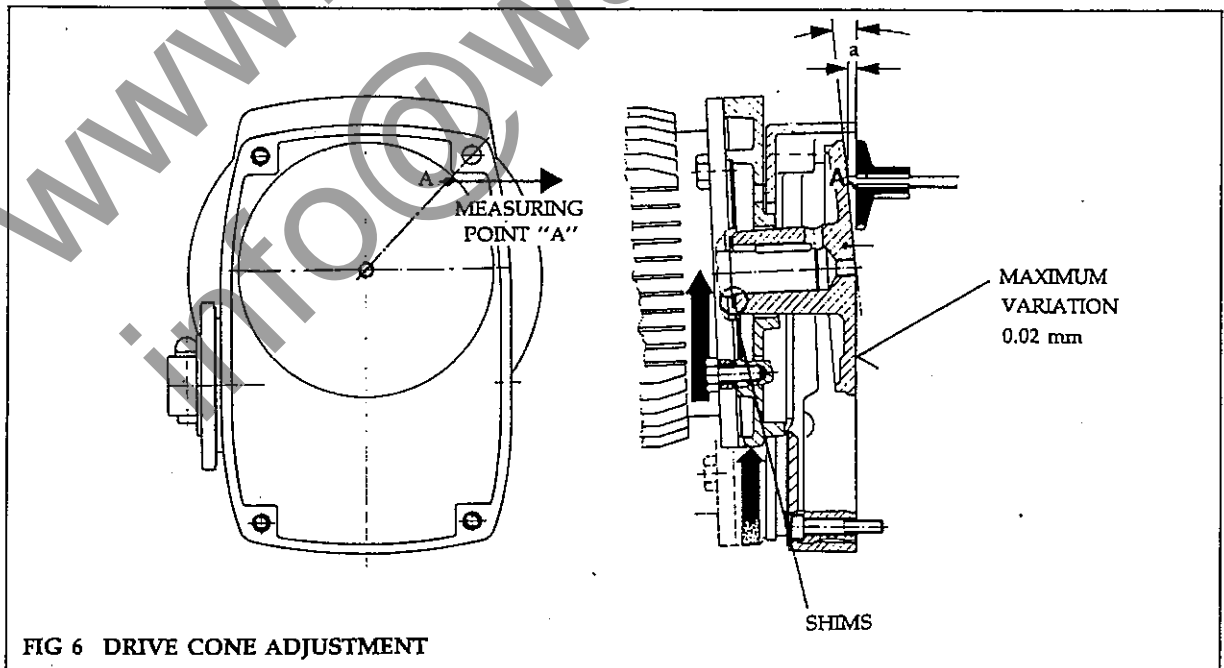

FIG 6 DRIVE CONE ADJUSTMENT

**Drive cone adjustment: (Fig 6)**

- (1) Remove the motor/split the gearbox assembly as for **Clean/Replace Friction Ring**, (Figs 4, 5).
- (2) Turn friction cone to the highest regulating position with the handwheel control. Check dimension 'a' at measuring point 'A' with a depth gauge.

- (3) Compensate for differences by turning the cone or adding shims at position indicated.

**Feed Roll Drives and Gearboxes (Fig 7)**

The GC woodworking machine is fitted with shaft drives; having a solid shaft drive to gearboxes mounted on the beam, with cardan shaft drives to the feed rolls. The power transfer to

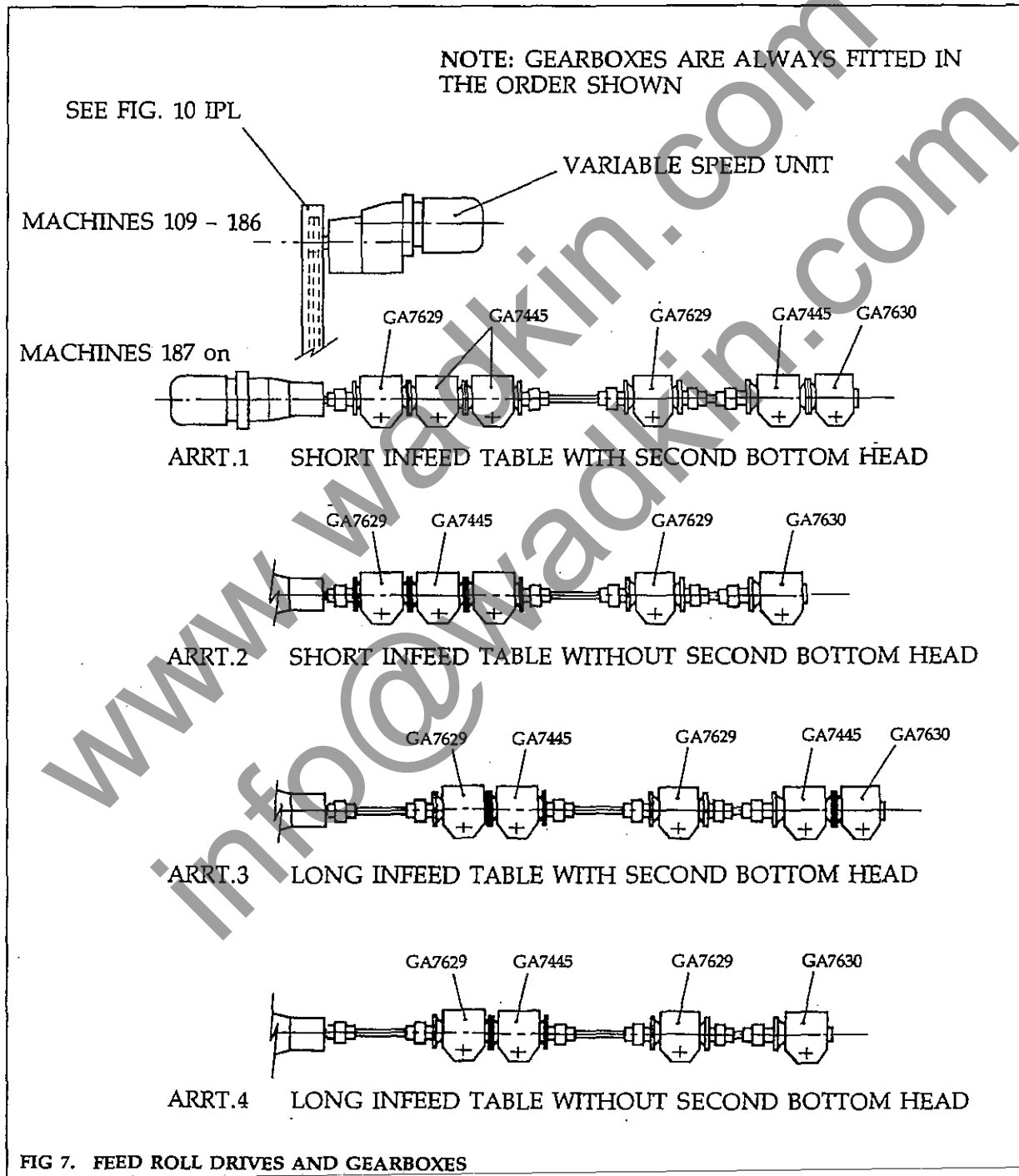

each feedroll is via a right-angle worm and wheel gearbox at each offtake.

**IMPORTANT NOTE:** It is important to note that although all the gearboxes look the same externally, there are fundamental differences internally, depending on location. The various gearbox arrangements on the GC machine are shown in Fig 7.

When replacing any gearbox, it is important to note the location and Reference No. (GA....) which is shown on a plate attached to the gearbox housing, otherwise the bearing arrangements may not be suitable for the work load.

For reference; gearbox GA 7629 is always located adjacent to the drive unit. This gearbox has a taper roller bearing fitted on the input end of the worm drive shaft in place of a radial bearing to carry the extra loading imposed. The worm shaft, which is solid with parallel keys at both ends, extends through the gearbox to locate with a mating coupling to gearbox GA 7445.

The intermediate gearboxes GA 7445, are also fitted with extended worm drive shafts. The end which extends through the gearbox is hollow with internal keyway to permit coupling via a flange to a further gearbox in-line. A thrust bearing is fitted to this end of the shaft to accommodate the axial load.

The end of line gearbox GA 7630, is a standard type gearbox with radial bearings. The worm shaft does not extend through the box.

### Spare Parts

When ordering spare parts, all the data shown on the unit nameplate must be quoted, together with Reference Numbers from the Illustrated Parts List.

### Cutters and Tool Holders

When choosing cutters, make sure they are suitable for the spindle speed. Dynamically balance and check for defects and cracks.

The life of a cutterblock is directly related to the quality of the steel and nature of timber to be worked. It is impossible to give exact values of cutter life; the following is a guide.

High speed steel	HLS	2 - 5 hours
Very high speed steel	HSS	3 - 8 hours
Carbide steel	HM	20 - 70 hours

Honing at regular intervals will prolong the life of the cutters.

When regrinding cutters it is very important to ensure the edge does not become overheated. Overheating can be prevented if light grinding cuts are taken.

Ensure that all cutters of a multiple cutterblock are the same, the objective being all should cut the timber evenly and equally.

The performance of any tool depends to a large extent on the care in the way it is used. The life of the cutters and the surface finish of the workpiece are directly related to the care which is given to the work.



## FAULT FINDING

### Mechanical Faults

Apart from mechanical failure (breakage) the majority of mechanical faults can be attributed to incorrectly tensioned drive chains or belts; the setting of cutterblocks and cutterblades; items working loose due to vibration — failure to set or tighten correctly; wrong speed setting; or misuse.

Therefore to get the best performance it is essential that the machine is set-up and used correctly, when many mechanical faults can be avoided.

### Electrical Faults

**FAULT** The machine does not run when any 'START' button is operated

#### Diagnosis

- a. Disconnect (isolator) switch has not been closed
- b. Main fuse or control circuit fuse has blown
- c. Overload relay has tripped

#### Remedial Action

- a. Check and close if needed
- b. Replace fuse
- c. Reset relay. Check reason for trip

**FAULT** A motor does not start — loud humming sound

#### Diagnosis

- a. An open circuit in at least two 'line leads' of the motor
- b. The fuses of the motor have blown

#### Remedial Action

- a. Check circuit and rectify
- b. Replace fuse

**FAULT** An air break magnetic contactor does not operate

#### Diagnosis

- a. The contacts are burned and make improper contact
- b. Broken connection wire
- c. An overload relay has tripped
- d. A fuse has blown

#### Remedial Action

- a. Clean or replace contacts
- b. Remake connections
- c. Reset relay. Check reason for overload
- d. Replace fuse

### Elimination of Vibration

It is important to check condition and tension of the cutter spindle drive belts regularly (see **Scheduled Maintenance**).

It is also important that the cutters are evenly ground and set to run true in the cutterblock, the assembled cutterblock should be statically balanced before fitting to the spindle.

In the case of high speed machines it is highly recommended that cutterblocks be dynamically balanced (see **Maintenance: Cutters and Toolholders**).

**FAULT** A Star/Delta connected motor does not operate when the contactor is connected in star

**Remedial Action**

Check/Remedy the symptoms outlined in paragraph above

**FAULT** When a motor is started, the fuses blow and the overload relay trips

**Diagnosis**

- a. The motor does not run freely
- b. There is a short circuit in the wiring mains
- c. The motor windings or winding are/is earthed

**Remedial Action**

- a. Check that the motor is free running
- b. Check the circuit wiring
- c. Check the windings in turn for electrical continuity and also earth faults with a 'Megger'

**FAULT** The motor overheats when running 'light' (unloaded)

**Diagnosis**

- a. The motor windings are connected in delta instead of star
- b. The mains voltage is too high
- c. The ventilating air ducts of the motor frame have become blocked with dust or chips, the cooling air passage has become impeded, or the cooling fan (if fitted) is not functioning correctly

**Remedial Action**

- a. Check connections
- b. Check mains voltage and correct
- c. Clean airways. Check fan operation

**FAULT** Motor overheats while working

**Diagnosis**

- a. The motor is overloading
- b. The motor is running under single phase conditions

**Remedial Action**

- a. Check reason and correct
- b. Check electrical circuits

**FAULT** The motor makes an abnormal noise

**Diagnosis**

- a. The cause can be of a mechanical or electrical nature
- b. If the noise is caused by an electrical fault, the noise will disappear when power is switched off
- c. If the noise is caused by a mechanical fault, the noise will diminish as speed of rotation decreases

**Remedial Action**

- a. Establish mechanical or electrical origin
- b.c. Check symptoms. Deduce by elimination to locate position and nature of fault



**FAULT** The Air Break Magnetic Starter is noisy

**Diagnosis**

- a. The mains voltage is too low
- b. The surfaces of the 'fixed' and 'moving' contacts are dirty

**Remedial Action**

- a. Check mains voltage and correct
- b. Clean or replace contacts

**FAULT** The air break magnetic starter remains 'closed' after a STOP button has been operated

**Diagnosis**

- a. The contactor 'fixed' and 'moving' contacts have welded together following a short circuit

**Remedial Action**

- a. Check and remove cause of the short circuit. Replace the damaged contacts. It may be necessary to replace the complete contactor if too damaged

**FAULT** A fault condition arises on a motor and the overload current relay fails to operate.

**Diagnosis**

- a. The overload relay may be incorrectly rated – it should correspond to the normal full load current of the motor (given on the motor nameplate) for Direct-on-Line starting
- b. If the overload relay is connected in a Star/Delta starter, the rating of the overload should be the normal full load current of the motor (given on the motor nameplate) multiplied by 1/1.73 (0.58)

**Remedial Action**

- a. Replace with correctly rated relay

**FAULT** A Spindle stops, but the motor still runs

**Diagnosis**

- a. The drive belts are loose, broken, or have come off

**Remedial Action**

- a. Retension or replace belts

**FAULT** The Rise and Fall drive motor does not operate

**Diagnosis**

- a. The limit switch on the top horizontal head, or the limit switch at the end of the machine is jammed by wood chips or is damaged
- b. The push button is faulty

**Remedial Action**

- a. Check and clean the limit switches
- b. Check and clean the push button

**FAULT** If the limit switch between the Top Head and Beam is operated simultaneously with either of the two Beam Vertical Traverse limit switches, the Beam will not lower

**Diagnosis**

Disengage the clutch on top head and manually wind down the top head until limit switch is released, then bring beam down by normal procedure (pushbutton control)

The foregoing observations are of a general nature and intended to be of assistance to avoid the incidence of breakdown. They do not preclude the user from calling a qualified electrician. In the case of an electrical fault or breakdown, in the interest of personal safety, it is always advisable to call a qualified electrician if the fault repeats.

## TABLES

## APPROVED LUBRICANTS

WADKIN	CASTROL	B.P.	SHELL	MOBIL	ESSO	GULF	CALTEX
L1	HYSPIN AWS 32	ENERGOL HLP 32	VITROL 32	DTE OIL LIGHT 24	NUTO 44 OR ESSTIC H44	HARMONY 43 AW	RANDO OIL HDA
L2	ALPHA ZN 150	ENERGOL HP 150 OR CS 150	VITREA 150	VACTRA EXTRA HEAVY	ESSTIC 65	SERVICE 13	URSA P40
L4	MAGNA 68	ENERGOL HP 68 OR CS 68	VITREA 68	VACTRAL OIL HEAVY MEDIUM	ESSTIC 50	SERVICE 51	URSA P20
L6	SPHEEROL AP 3	ENERGREASE LS3	ALVANIA GREASE NO. 3	MOBILPLEX GREASE NO. 48	BEACON 3	GULFCROWN GREASE NO. 3	REGAL STARTAK PREMIUM 3

- L1 OIL Hydraulic oil with anti-corrosion, anti-oxidation, anti-wear, anti-foam performance.
- L2 OIL Gear oil (Viscosity 150 centi-strokes at 40°C).
- L4 OIL Plain mineral oil (Viscosity 68 centi-strokes at 40°C).
- L6 GREASE Grease NLG1 No. 3 consistency Lithium bearing grease.

The worm drive gearboxes are supplied filled to the correct level with a semi-fluid grease, IP Tevela Compound A. No maintenance will normally be required on these gearboxes which are sealed for life.

The variable speed unit (Stober) gearbox can be refilled with Wadkin L2 oil.



## MOTOR AND DRIVE BELT DATA

Belts and pulleys for spindle drive to FIRST AND SECOND BOTTOM HEADS Frequency 50 Hertz												
Motor			Motor Pulley		Taper Lock Bush			Belts			Spindle Pulley	Spindle Speed
Frame Size	K.W.	H.P.	Fenner Ref.	Wadkin Code	Bore M.M.	Fenner Ref.	Wadkin Code	Fenner Ref.	Wadkin Code	Quan.	Wadkin Number	R.P.M.
D132	5.5	7.5	031Z 0223	K30 78 218	38	2012	K30 77 113	SPZ 850	K30 78 213	3	GA 410	6000
D112	5.5	7.5	031Z 0223	K30 78 218	28	2012	K30 77 114	SPZ 850	K30 78 213	3	GA 410	6000

Belts and pulleys for spindle drive to FIRST AND SECOND BOTTOM HEADS Frequency 60 Hertz												
Motor			Motor Pulley		Taper Lock Bush			Belts			Spindle Pulley	Spindle Speed
Frame Size	K.W.	H.P.	Fenner Ref.	Wadkin Code	Bore M.M.	Fenner Ref.	Wadkin Code	Fenner Ref.	Wadkin Code	Quan.	Wadkin Number	R.P.M.
D132	5.5	7.5	031Z 0203	K30 78 272	38	2012	K30 77 113	SPZ 800	K30 78 208	3	GA 410	6000
D112	5.5	7.5	031Z 0203	K30 78 272	28	2012	K30 77 114	SPZ 800	K30 78 208	3	GA 410	6000

Belts and pulleys for spindle drive to FENCE SIDE HEAD Frequency 50 Hertz												
Motor			Motor Pulley		Taper Lock Bush			Belts			Spindle Pulley	Spindle Speed
Frame Size	K.W.	H.P.	Fenner Ref.	Wadkin Code	Bore M.M.	Fenner Ref.	Wadkin Code	Fenner Ref.	Wadkin Code	Quan.	Wadkin Number	R.P.M.
D112	4.0	5.5	031Z 0222	K30 78 297	28	2012	K30 77 114	SPZ 850	K30 78 213	2	GA 109	6000

Belts and pulleys for spindle drive to FENCE SIDE HEAD Frequency 60 Hertz												
Motor			Motor Pulley		Taper Lock Bush			Belts			Spindle Pulley	Spindle Speed
Frame Size	K.W.	H.P.	Fenner Ref.	Wadkin Code	Bore M.M.	Fenner Ref.	Wadkin Code	Fenner Ref.	Wadkin Code	Quan.	Wadkin Number	R.P.M.
D112	4.0	5.5	031Z 0202	K30 78 294	28	1610	K30 77 184	SPZ 800	K30 78 208	2	GA 109	6000





Belts and pulleys for spindle drive to			NEAR SIDE HEAD					Frequency 50 Hertz				
Motor			Motor Pulley		Taper Lock Bush			Belts			Spindle Pulley	Spindle Speed
Frame Size	K.W.	H.P.	Fenner Ref.	Wadkin Code	Bore M.M.	Fenner Ref.	Wadkin Code	Fenner Ref.	Wadkin Code	Quan.	Wadkin Number	R.P.M.
D112	5.5	7.5	031Z 0223	K30 78 218	28	2012	K30 77 114	SPZ 850	K30 78 213	3	GA 410	6000

Belts and pulleys for spindle drive to			NEAR SIDE HEAD					Frequency 60 Hertz				
Motor			Motor Pulley		Taper Lock Bush			Belts			Spindle Pulley	Spindle Speed
Frame Size	K.W.	H.P.	Fenner Ref.	Wadkin Code	Bore M.M.	Fenner Ref.	Wadkin Code	Fenner Ref.	Wadkin Code	Quan.	Wadkin Number	R.P.M.
D112	5.5	7.5	031Z 0203	K30 78 272	28	2012	K30 77 114	SPZ 800	K30 78 208	3	GA 410	6000

Belts and pulleys for spindle drive to			TOP HEAD					Frequency 50 Hertz				
Motor			Motor Pulley		Taper Lock Bush			Belts			Spindle Pulley	Spindle Speed
Frame Size	K.W.	H.P.	Fenner Ref.	Wadkin Code	Bore M.M.	Fenner Ref.	Wadkin Code	Fenner Ref.	Wadkin Code	Quan.	Wadkin Number	R.P.M.
D132	7.5	10.0	031Z 0223	K30 78 218	38	2012	K30 77 113	SPZ 850	K30 78 213	3	GA 410	6000

Belts and pulleys for spindle drive to			TOP HEAD					Frequency 60 Hertz				
Motor			Motor Pulley		Taper Lock Bush			Belts			Spindle Pulley	Spindle Speed
Frame Size	K.W.	H.P.	Fenner Ref.	Wadkin Code	Bore M.M.	Fenner Ref.	Wadkin Code	Fenner Ref.	Wadkin Code	Quan.	Wadkin Number	R.P.M.
D132	7.5	10.0	031Z 0203	K30 78 272	38	2012	K30 77 113	SPZ 800	K30 78 208	3	GA 410	6000

**SECTION 5 — ILLUSTRATED PARTS LIST****CONTENTS**

- 1 Bedplates Fences and Side Guide
- 2 First and Second Bottom Heads
- 3 Top Head including Power Rise and Fall
- 4 Top Head Axial Adjustment
- 5 Fence and Near Side Head Carriage Assembly
- 6 Top Head Chipbreaker, Pressure pad and extraction hood
- 7 Near Side Head Chipbreaker and extraction hood
- 8 Variable Speed Drive Unit
- 9 Feed Roll Drives
- 9A Cardan Shafts
- 10 Feed Roll Belt Drive
- 11 Single Side Roller Pressure Unit
- 12 Top Roller Pressure Unit
- 13 Beam Power Rise and Fall
- 14 All Spindle Units

**IMPORTANT: WHEN ORDERING SPARES ALWAYS QUOTE MODEL AND MACHINE NUMBER**

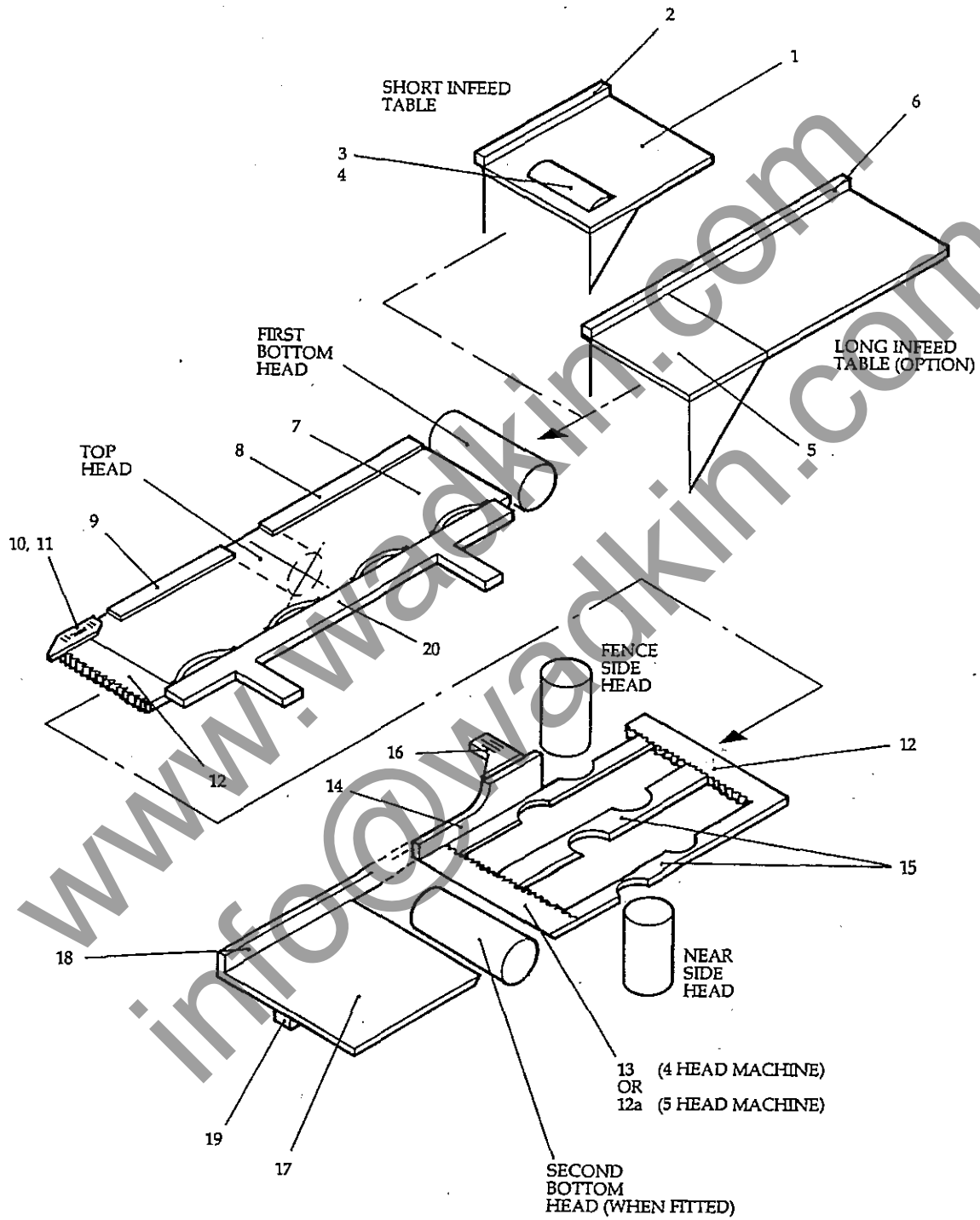

FIG 1 BEDS FENCES AND SIDE GUIDE

## 1. BEDPLATES FENCES AND SIDE GUIDE

Ref. No.	Description	No. Off
1	Bedplate, short infeed table	1
2	Fence, short infeed table	1
3	Bed roller, short infeed table	1
4	Bed roller shaft, for above	1
5	Nose piece, long infeed table	1
6	Fence, long infeed table	1
7	Bedplate, under top head	1
8	Fence, before top head	1
9	Fence, after top head	1
10	Nose piece, GA6310	1
11	Clamping plate, serrated	1
12	Bedplate, before side heads	1
12a+	Bedplate, before/after side heads	2
13	Bedplate, after side heads	1
14	Fence short, after fence side head	1
15	Infill bar, side heads, GA7824	3
16	Bracket, fence, after fence side head	1
17	Bedplate, after 2nd bottom head	1
18	Fence long, after fence side head	1
19	Tenon, outfeed table	1
20	Side guide	1

+ On GC4 + 1 (5 head machine)

The following items are not illustrated

	Front fence support bracket	2
	Front fence support	2
Part of 20	Leaf spring	4
	Cap head screw, M5 × 10mm	8



ITEMS 1 TO 4 ONLY ON FIRST BOTTOM HEAD

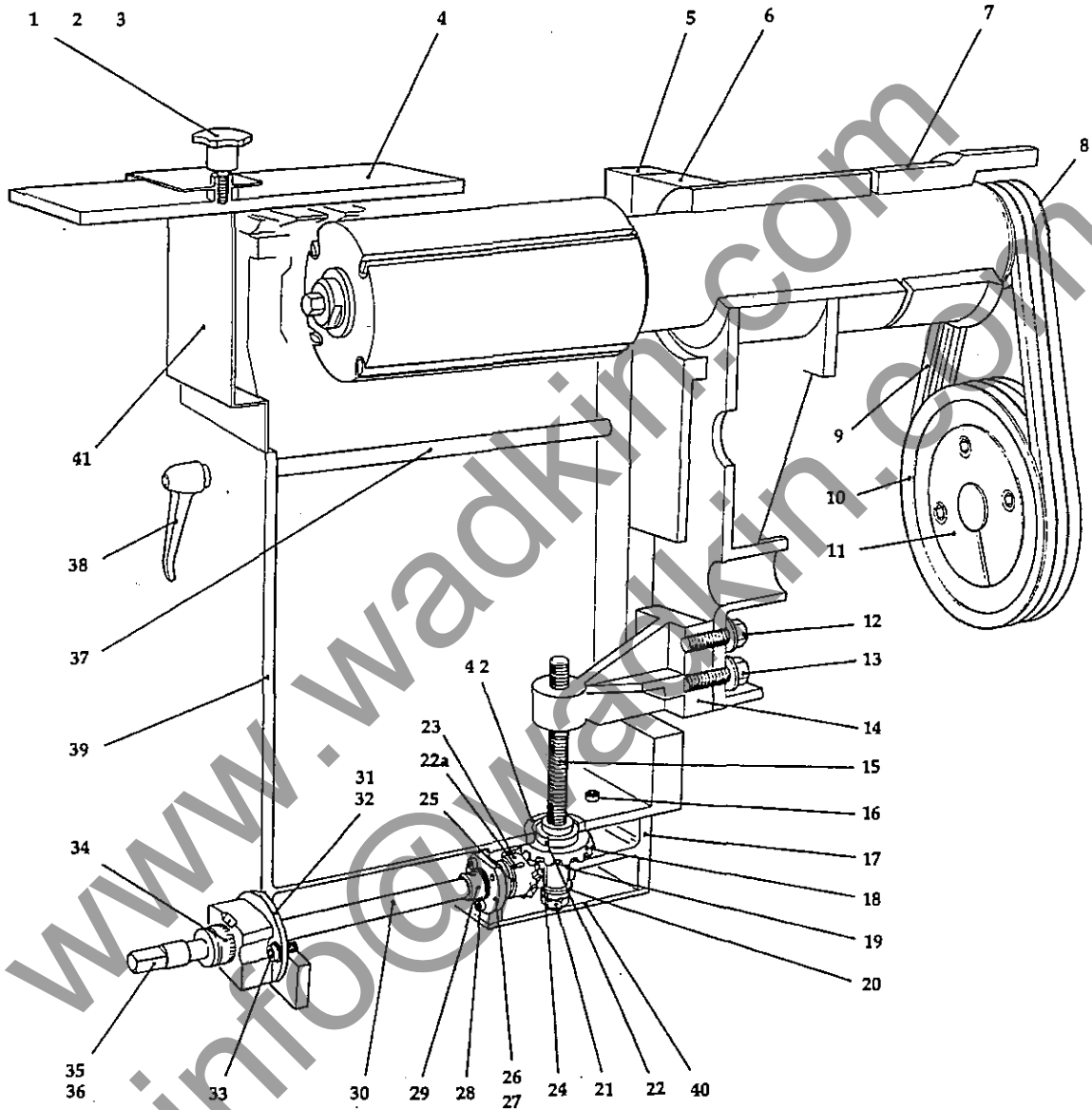

FIG 2. FIRST AND SECOND BOTTOM HEADS

## 2. FIRST AND SECOND BOTTOM HEADS

Ref. No.	Description	No. Off
1	Handwheel, standard, black plastic moulding, M12 blind hole	1
2	Locking screw for guard, First Bottom Head cutterblock	1
3	Locking pad for cutterblock guard	1
4	Top sliding guard, First Bottom Head	1
5	Slide strip	1
6	Bottom Head spindle housing, vertical slide	1
7	Pulley belt housing, horizontal heads	1
8	Spindle pulley, Bottom and Top Heads	1
9	Fenner vee belt, SPZ 850	2 or 3
10	Fenner vee belt pulley	1
11	Fenner Taper-Lock bush	1
12	Hexagon head screw, M10 x 30mm long	4
13	Spring washer, 10mm diameter, single coil	4
14	Bracket nut, Bottom Head vertical adjustment	1
15	Vertical adjustment screw, First Bottom Head	1
16	Hexagon socket capscrews, M6 x 75mm long	4
17	Bevel box, Bottom Head vertical adjustment	1
18	Bevel gear wheel	1
19	Bearing washer, top and bottom	2
20	Thrust washer	1
21	M16 hexagonal nut	2
22	Parallel key 5mm x 5mm x 20mm long	1
22a	Parallel key 8mm x 7mm x 20mm long	1
23	Bevel gear pinion	1
24	Circlip, 16mm external, pinion shaft (not shown)	1
25	Thrust washer	1
26	Bronze bush, 25mm ID x 30mm OD x 25mm long	1
27	End cap, bevel box	1
28	Hexagon socket capscrews, M6 x 20mm long	3
29	Collar	1
30	Extension shaft, bevel gear	1
31	Bearing bracket, extension shaft	1
32	Bronze bush, 20mm ID x 25mm OD x 25mm long	2
33	Hexagon socket capscrews, M6 x 20mm long	2
34	Calibrated dial, GA 6768	1
35	Square end shaft extension	1
36	Taper pin, No.5	1
37	Extension shaft, vertical lock	1
38	Locking handle, M12 x 25mm, male	1
39	Main Frame	1
40	Cover, bevel box	1
41	Front guard, Bottom Head spindles	1
42	Top cover, bevel gear	1

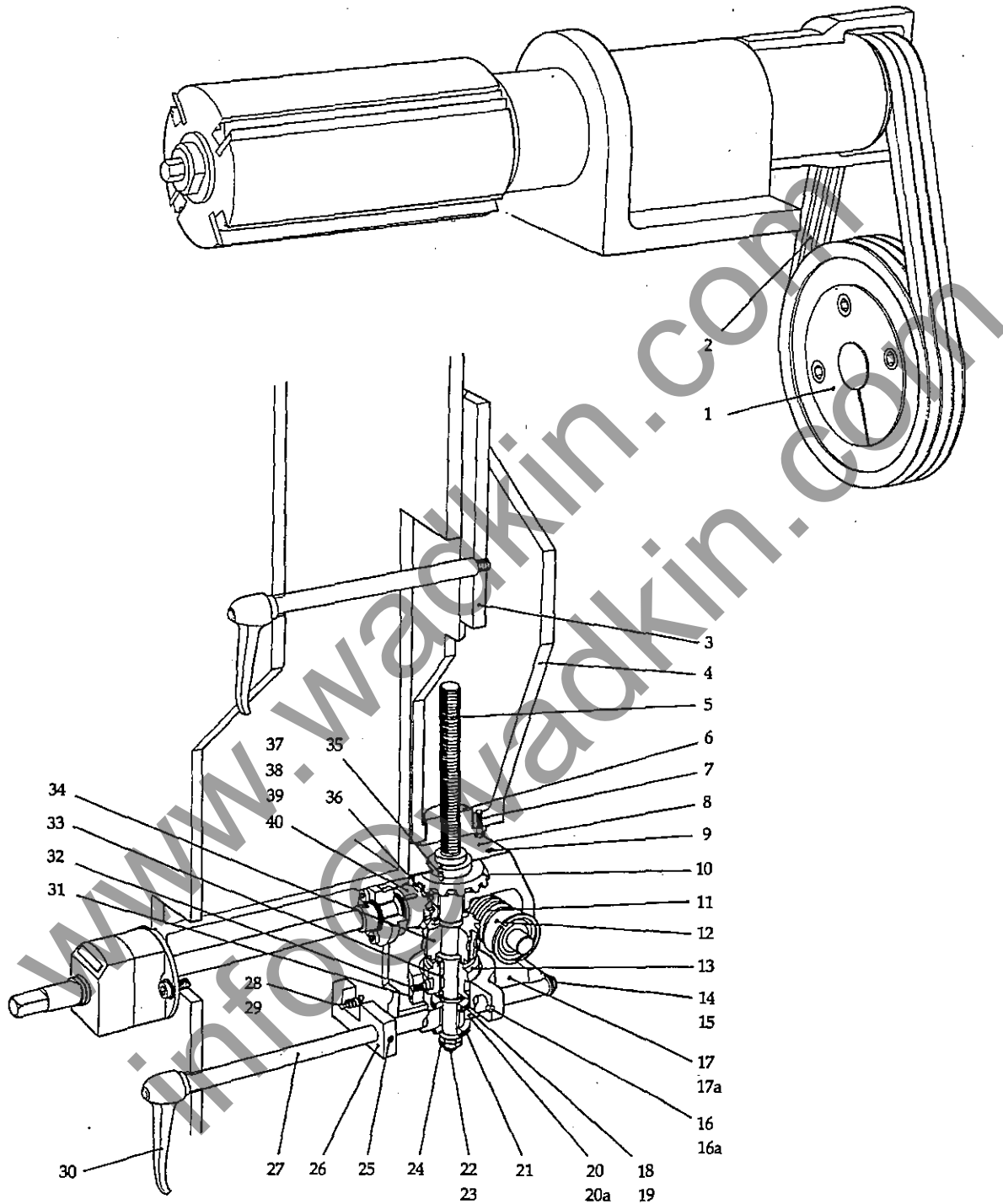

FIG 3 TOP HEAD INCLUDING POWER RISE AND FALL

## 3. TOP HEAD INCLUDING POWER RISE AND FALL

Ref. No.	Description	No. Off
1	Fenner vee belt pulley	1
2	Fenner vee belt, SPZ 850	2 or 3
3	Slide strip	1
4	Top Head vertical slide	1
5	Vertical screw, Top Head rise and fall	1
6	Bracket nut, Top Head rise and fall	1
7	Hexagon head screws, M8 x 25mm long	2
8	Top cover, gearbox/clutch housing	1
9	Socket head capscrews, M6 x 10mm long	4
10	Bevel gear wheel	1
11	Worm gear, rise and fall top beam/head	1
12	Bearing, 6204 RS	2
13	Dogclutch, Top Head rise and fall	1
14	Circlip, 16mm external (not shown)	1
15	Spacer washer	1
16	Tension pin, 6mm x 32mm long	1
16a	Hexagon socket screw cup point, M6 x 6mm long	1
17	Gearbox/clutch housing	1
17a	Socket head capscrews, M12 x 30mm long	4
18	Spacer washer	2
19	Circlip, 30mm external	2
20	Bottom cover, gearbox/clutch housing	1
20a	Securing screws, M8 x 16mm hex. socket	4
21	Thrust washer	2
22	Plain washer, 16mm	1
23	M16 hexagon nut	2
24	Bronze bush, 25mm ID x 30mm OD x 20mm long	1
25	Hexagon socket screw, cup point, M6 x 10mm long	1
26	Clutch location arm	1
27	Clutch shaft	1
28	Spring, clutch location arm lock	1
29	Steel ball, 10mm diameter	1
30	Locking handle, M10 x 25mm, male	1
31	Clutch yoke, top head rise and fall	1
32	Hexagon socket capscrews, M6 x 10mm long	2
33	Parallel key, 8mm x 7mm x 32mm long	1
34	Worm wheel, Top Head rise and fall	1
35	Parallel key, 8mm x 7mm x 14mm long	1
36	Bronze bush, 30mm ID x 35mm OD x 20mm long	1
37	Circlip, 16mm external (not shown)	1
38	Parallel key, 5mm x 5mm x 20mm long	1
39	Spacer washer	2
40	Bevel gear, pinion	1



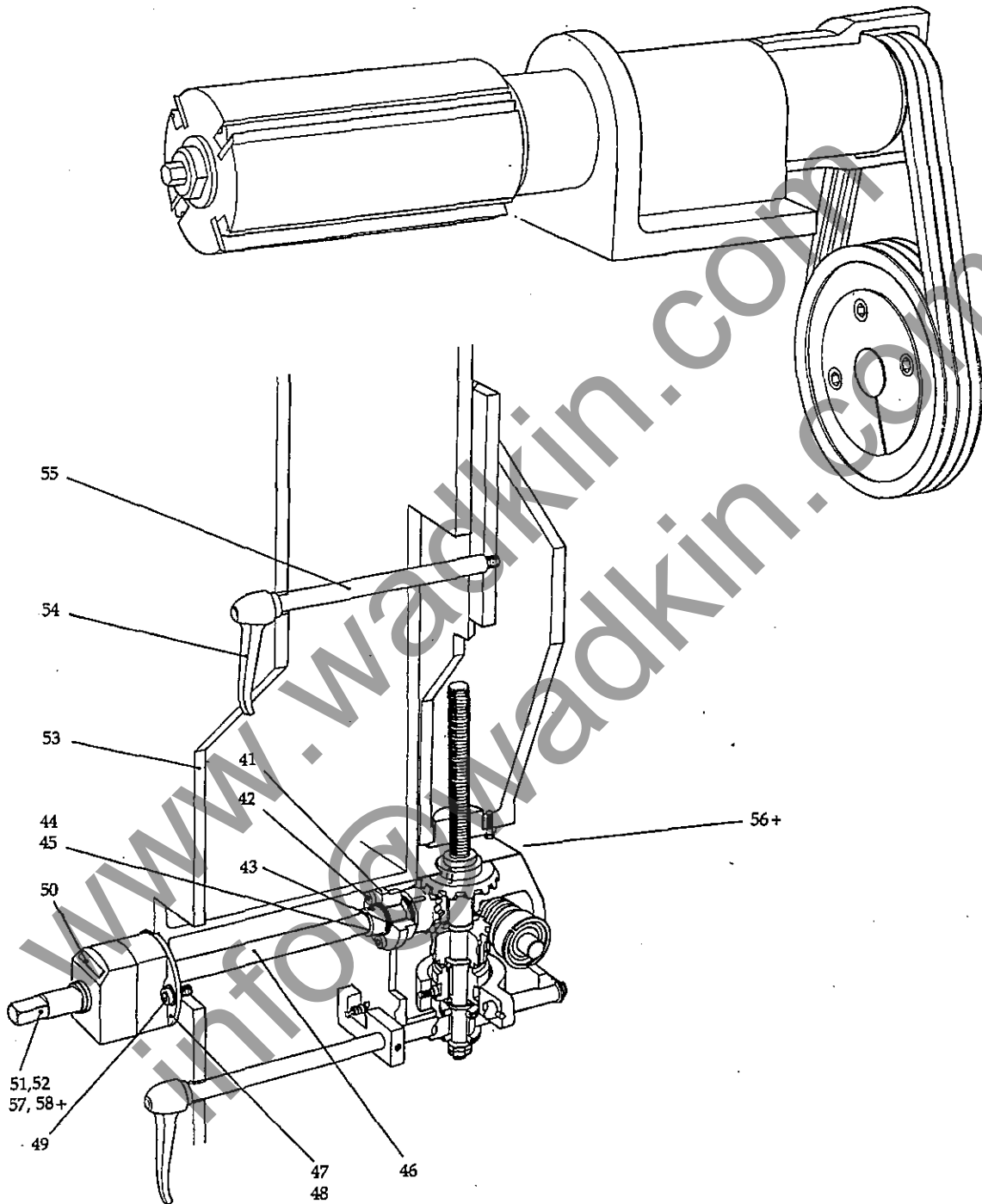

FIG. 3., TOP HEAD INCLUDING POWER RISE AND FALL

## 3, TOP HEAD INCLUDING POWER RISE AND FALL (cont.)

Ref. No.	Description	No. Off
41	End cap, bevel box	1
42	Socket head capscrew, M6 × 20mm long	3
43	Bronze bush, 20mm ID × 25mm OD × 25 long	1
44	Collar	
45	Hex. socket screw - cup point, M6 × 6mm long	1
46	Extension shaft	1
47	Bearing bracket, extension shaft	1
48	Bronze bush, 20mm ID × 25mm OD × 25mm long	1
49	Hex. socket capscrews, M6 × 20mm long	2
50	Digital readout	1
51	Square end shaft extension	1
52	Taper pin, No. 1	1
53	Main frame	1
54	Locking handle	1
55	Extension shaft, vertical lock	1
56+	Hex. head screw, M12 × 30mm	4
57+	Circlip	1
58+	Spring      Safety feature	1

+ Not illustrated. Attachment of gearbox/clutch housing to mainframe.

www.wadkin.com  
info@wadkin.com

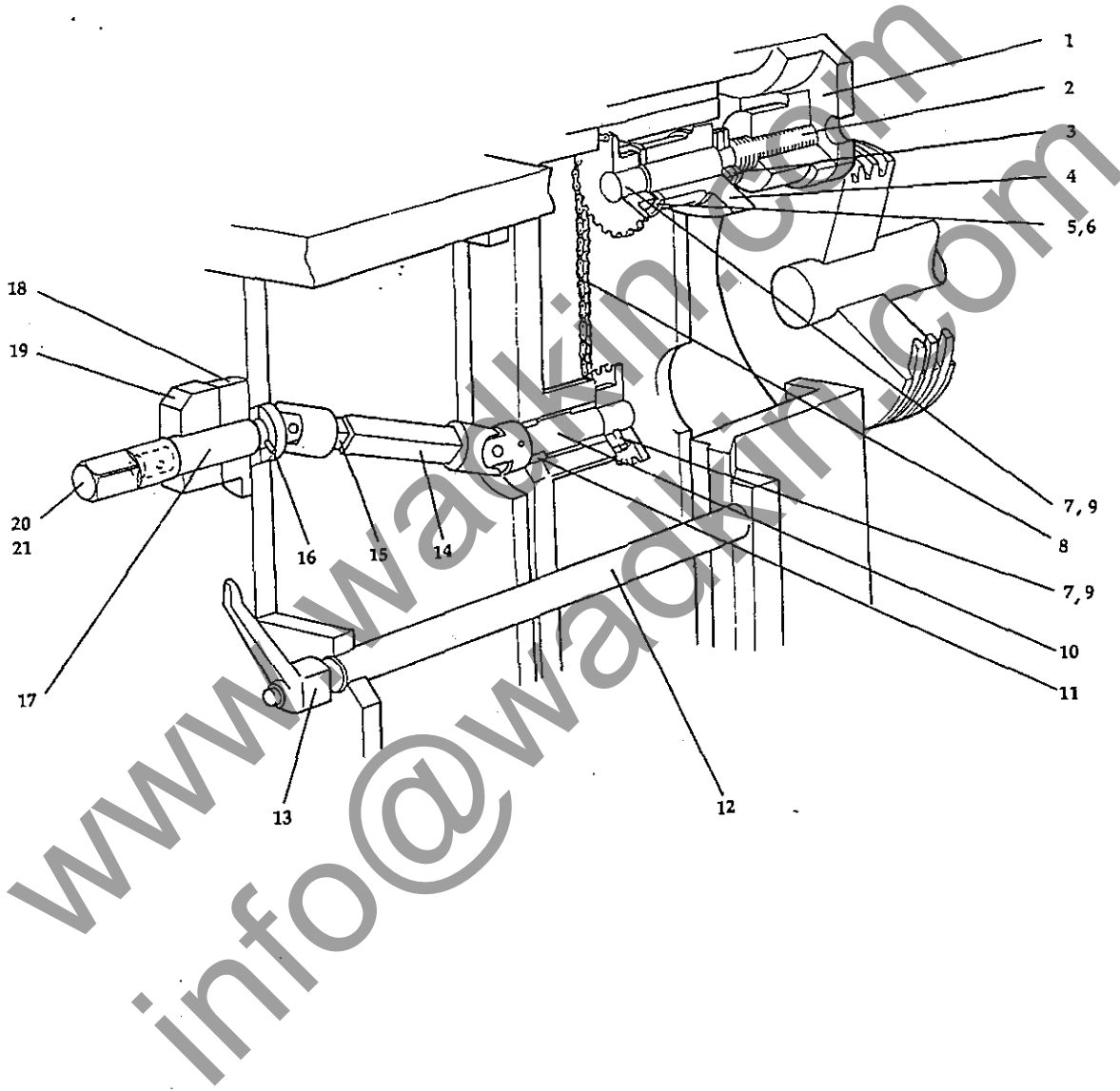

FIG. 4 TOP HEAD AXIAL ADJUSTMENT

## 4. TOP HEAD AXIAL ADJUSTMENT

Ref. No.	Description	No. Off
1	Nut for horizontal head adjustment	1
2	Shaft for horizontal head adjustment	1
3	M24. × 1.5 chamfered notch nuts	2
4	Bearing bracket for horizontal adjustment	1
5	'INA' bearings AXK 2542	2
6	'INA' bearings AS 2542	4
7	Sprocket for horizontal head axial adjustment	2
8	'RENOLD' Roller chain No. 111046 12.9mm (1/2in.) pitch, 40 pitches including connecting link	1
9	No. 4. taper pin	2
10	Shaft	1
11	20mm. I.D. × 25mm. O.D. × 20mm. long bronze brush	2
12	Extension for vertical lock to horizontal heads	1
13	Locking handle M12. × 25mm. male	1
14	Universal coupling and square tube assembly for horizontal head adjustment	1
15	Universal coupling and square tube assembly for horizontal head cross adjustment	1
16	6mm. dia. × 32mm. long tension pin	1
17	Shaft for horizontal head cross adjustment	2
18	Bearing block	1
19	Digital readout	1
20	Square shaft extension	1
21	Taper pin. No. 1	1

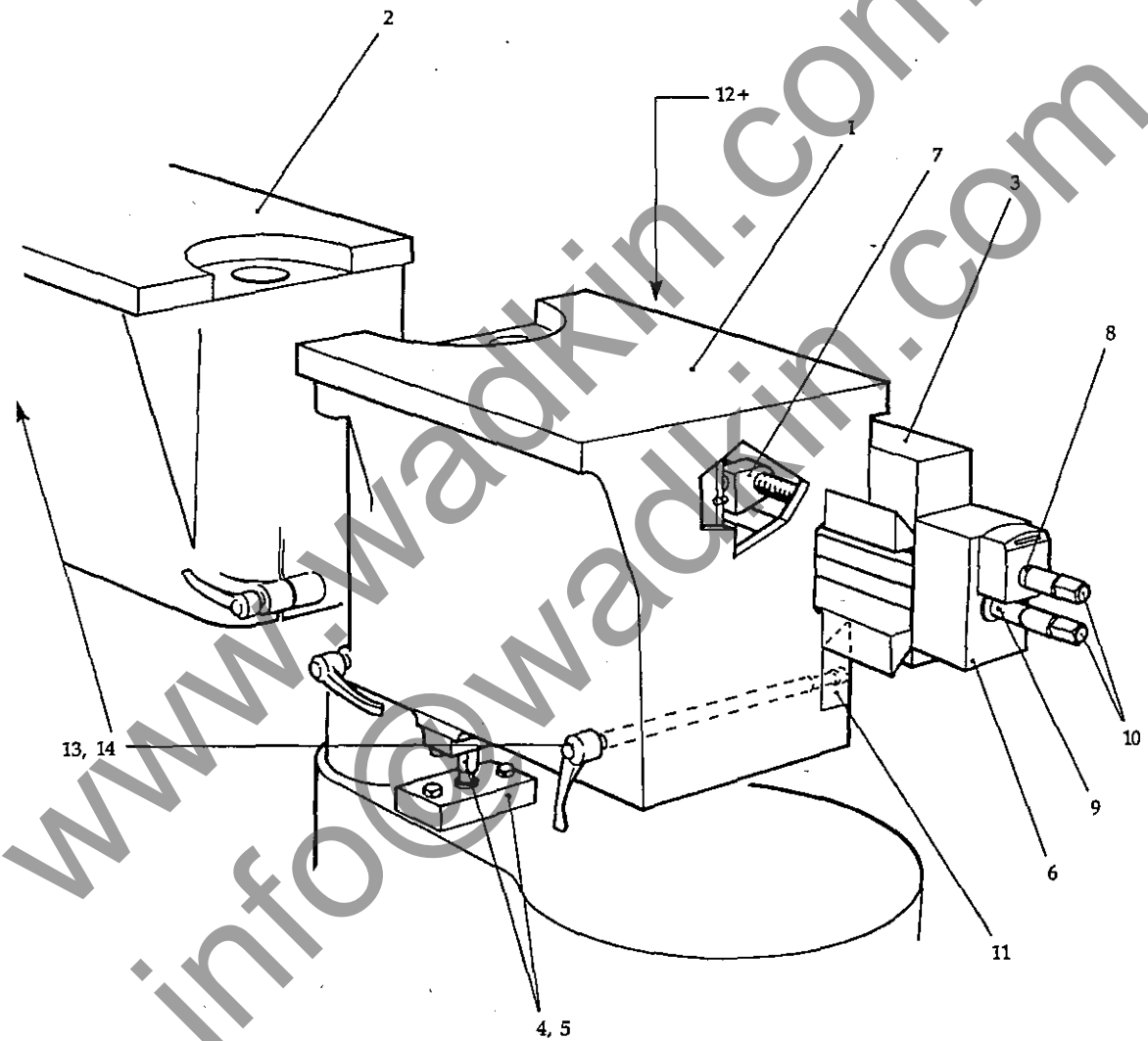

FIG 5. FENCE & NEAR SIDE CARRIAGE ASSEMBLY

**5. FENCE AND NEAR SIDE HEAD  
CARRIAGE ASSEMBLY**

Ref. No.	Description	No. Off
1	Horizontal slide, Near side head	1
2	Horizontal slide, Fence side head	1
3	Cross slide	1
4	Vertical adjustment screw for side heads	2
5	Adjustment nut for side heads	2
6	Bracket, side head adj. screw	1
7	Nut, side head horizontal adj.	2
8	Horizontal screw, Near side head	1
9	Horizontal screw, Fence side head	1
10	Square end shaft extension	2
11	Vee strip for FSH and NSH	2
12+	Cover, for cross slide	2
13	Locking shaft, FSH and NSH	2
14	Locking handle	2

+ Not illustrated

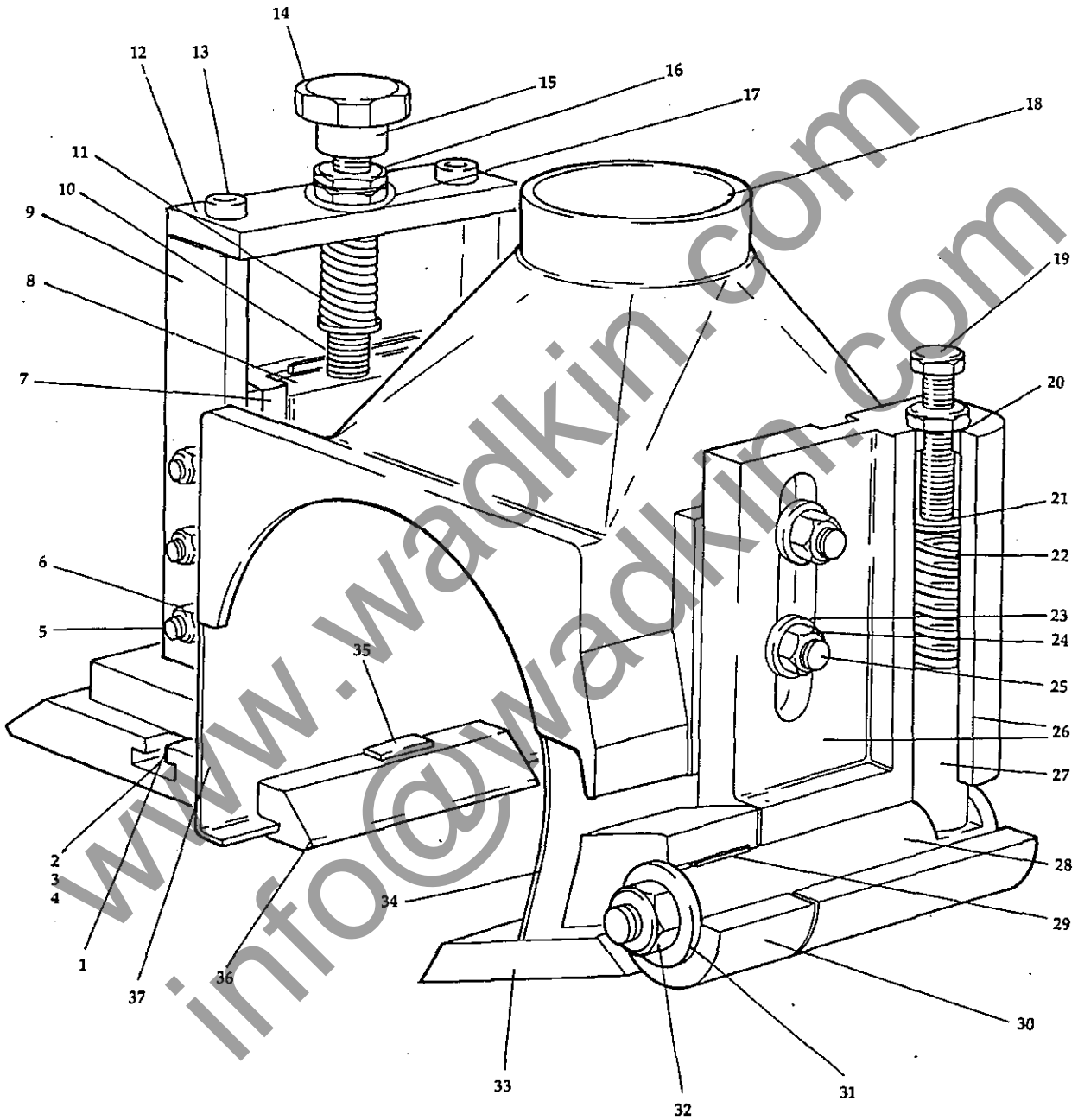

FIG 6 TOP HEAD CHIPBREAKER, PRESSURE PAD AND EXTRACTION HOOD

## 6. TOP HEAD CHIPBREAKER, PRESSURE PAD AND EXTRACTION HOOD

Ref. No.	Description	No. Off
1	Tee-nut, M10, ref. WDS 664 203	2
2	Screwed stud, M10 x 45mm long	2
3	Washer 10mm, bright mild steel	2
4	Hexagon nut, M10	2
5	Hexagon socket screws, half dog point, M6 x 35mm long	3
6	Hexagon nut, M6	3
7	Gib strip, rise and fall bracket, Top Head pressure pad	1
8	Slide, rise and fall, for shoe Top Head pressure pad	1
9	Bracket, rise and fall, Top Head pressure	1
10	Screw, raise/lower, Top head pressure pad	1
11	Compression spring, Top Head pressure pad	1
12	Top plate, Top Head pressure pad	1
13	Hexagon socket screw, M8 x 20mm long	2
14	Handwheel, M12 blind hole	1
15	Taper pin. No.0	1
16	Hexagon nut, thin, M12	2
17	Washer, 12mm, bright mild steel	1
18	Exhaust hood, Top Head	1
19	Hexagon head screw, M12 x 40mm long	1
20	Plug, spring loaded Top Head chipbreaker	1
21	Cap, Top Head chipbreaker spring	1
22	Spring, Top head chipbreaker	1
23	Washer, 10mm, bright mild steel	2
24	Hexagon nut, M10	2
25	Screwed stud, M10 x 50mm long	2
26	Pivot bracket, Top Head chipbreaker	1
27	Plunger, spring loaded Top Head chipbreaker	1
28	Pivot shaft, Top Head chipbreaker	1
29	Parallel key, 8mm x 6mm x 32mm long	1
30	Holder, Top Head chipbreaker shoe	1
31	Washer, chipbreaker pivot shaft	1
32	Nut, M12, self locking	1
33	Shoe, Top Head, 70mm long	1
34	Chip deflector, Top Head chipbreaker	1
35	Cross tenon for shoe, top head pressure	1
36	Shoe, Top Head pressure	1
37	Cover, Top Head pressure pad	1



## 7. NEAR SIDE HEAD CHIPBREAKER AND EXTRACTION HOOD

Ref. No.	Description	No. Off
1	Spring clip	2
2	Shoulder pin, M16 dia.	2
3	Spacer, M20 dia.	2
4	Top cover for Near Side Head hood	1
5	Exhaust Hood for Near Side Head	1
6	Post	2
7	Near Side head chip deflector	1
8	Spring	2
9	Hexagon socket capscrew, M8×10mm	4
10+	Hexagon socket countersunk screw, M8×10mm	2
11	Pivot pin for Near Side head chipbreaker	1
12	Near Side head and chipbreaker shoe pivot bracket	1
13+	Cup point grub screw, M8×12mm	4
14	Hexagon full nut, M8	1
15	Hexagon head screw, M8×40mm	1
16	Near Side head hood and chipbreaker shoe	1
17+	Screwed stud, 10mm×60mm, M10	1
18	Washer, 10mm	3
19	Locking handle, M10 female	1
20	Adjusting bar for Near Side head chipbreaker	1
21	Hexagon head screw, M10×25mm	2
22	Shoe chipbreaker bracket	1
23+	Side Cover for Near Side Head Hood	1
24+	Screwed Stud, 6mm×25mm, M6	2
25+	Washer, 6mm	2
26	Wing Nut M6	2
+	Not illustrated	

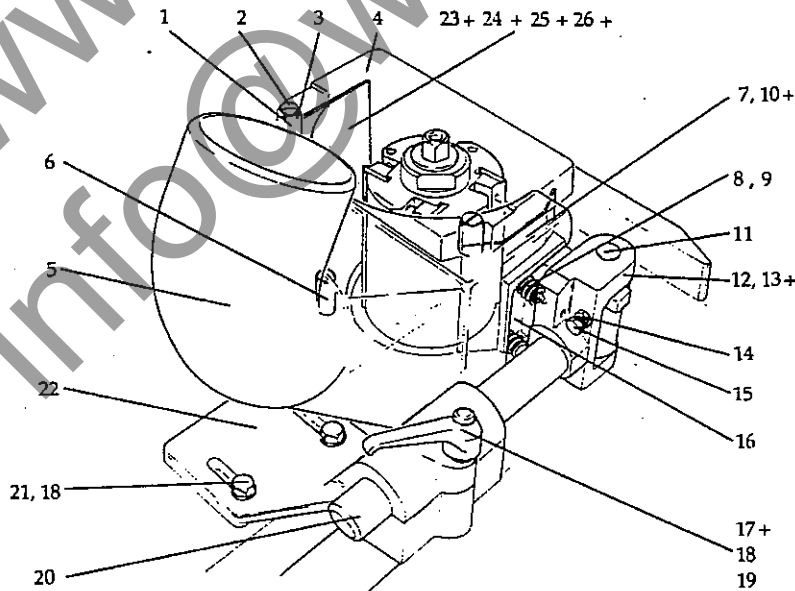

FIG. 7 NEAR SIDE HEAD CHIPBREAKER AND EXTRACTION HOOD

8. VARIABLE SPEED DRIVE UNIT

Ref. No.	Description	No. Off
1	Motor slide, standard	1
2	Main housing cover	1
3	Friction cone, standard	1
-	Shim rings	A/R
4	Friction ring, insert type	1
5	Friction ring flange, with shaft	1
6	Roller bearing	1
7	Gearbox housing, first stage, foot mtg.	1
8	Centering ring, with oil felt	1
9	Input shaft, with pinion, c/w Nos. 10 and 18	1
10	Roller bearing	1
11	Gearwheel, first stage	1
12	Output shaft	1
13	Cover, output side	1
14	Oil seal, for output shaft	1
15	Roller bearing	1
16	Roller bearing	1
17	Gasket	1
18	Compression spring	1
19+	Control wheel/shaft	1
20+	Locking handle or clamp screw	1
21+	Scale	1
+	Not illustrated	

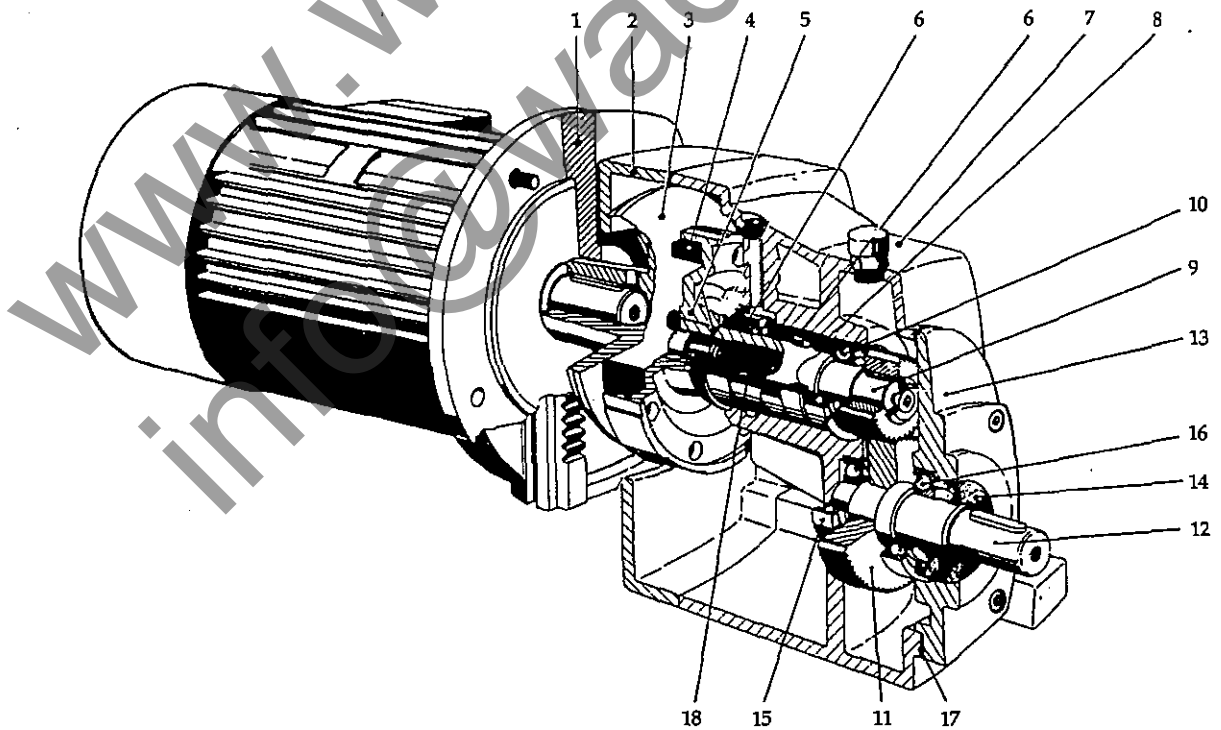
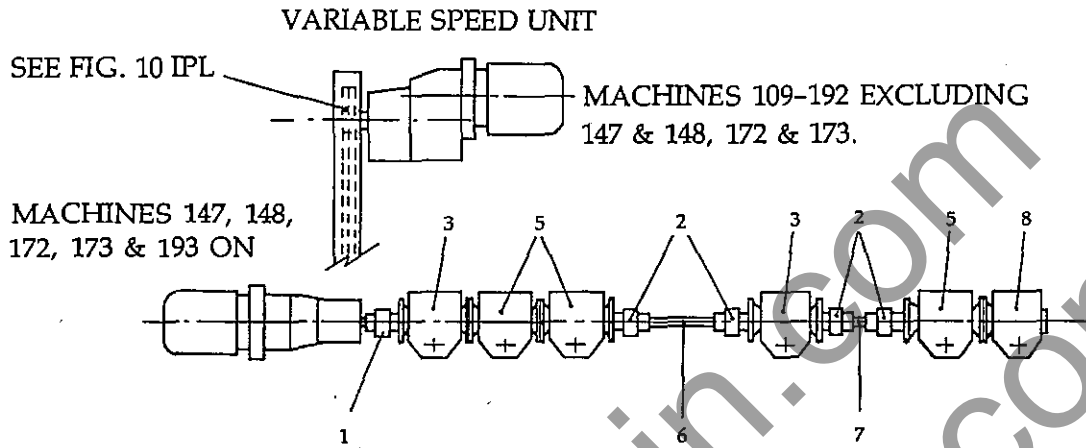

FIG 8 VARIABLE SPEED DRIVE UNIT



NOTE: GEARBOXES ARE ALWAYS FITTED IN THE ORDER SHOWN



ARRT.1 SHORT INFEED TABLE WITH SECOND BOTTOM HEAD

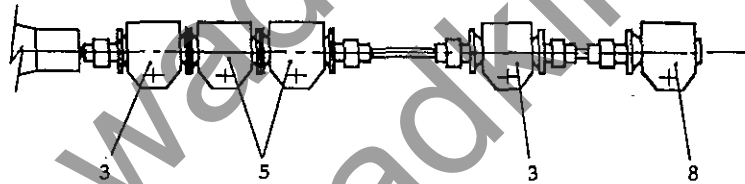

ARRT.2 SHORT INFEED TABLE WITHOUT SECOND BOTTOM HEAD

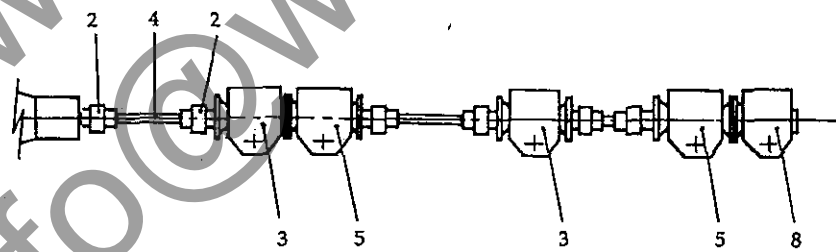

ARRT.3 LONG INFEED TABLE WITH SECOND BOTTOM HEAD

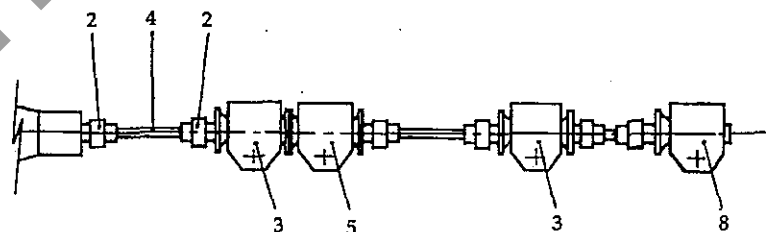

ARRT.4 LONG INFEED TABLE WITHOUT SECOND BOTTOM HEAD

FIG 9 FEED ROLL DRIVES AND GEARBOXES

9 A. FEED ROLL DRIVES AND GEARBOXES

Ref. No.	Description	No. Off
	Arrangements 1-4 as Figure	See Arrt
1	Coupling 19mm bore GA 7001 - Gear ring K30.09.899 - 19mm bore GA7001	
2	Coupling 19mm bore GA 7001 - Gear ring K30.09 899 - 19mm hex GA 6801	
3	Gearbox GA 7629	
4	Drive shaft GA 6796	
5	Gearbox GA 7445	
6	Drive shaft GA 6799	
7	Drive shaft GA 6788	
8	Gearbox GA 7630	

9A. CARDAN SHAFTS

9	Cardan shaft	See Arrt
10	Cover, flexible	
11	Clips	

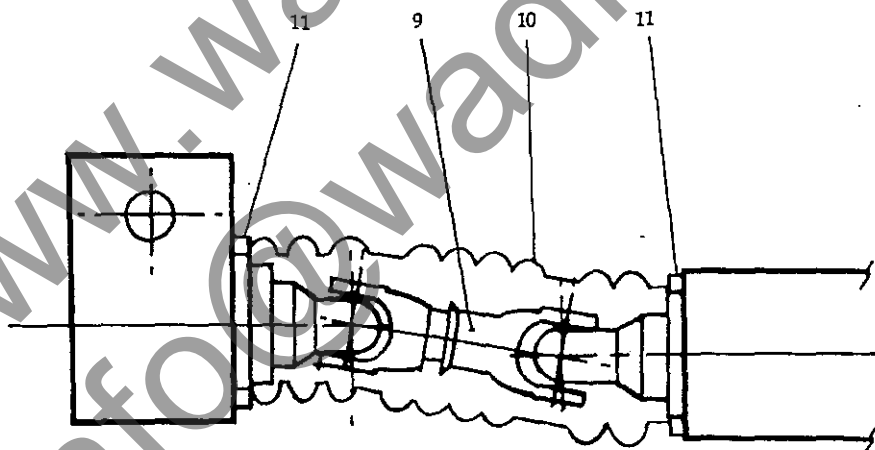

FIG 9A. CARDAN SHAFTS



## 10. FEED ROLL BELT DRIVE—M/C 109 TO 192 EXCLUDING 147, 148, 172 &amp; 173

Ref. No.	Description	No. Off
1	Drive mounting plate	1
2	Drive guard	1
3	Pan head screw, 6mm × 10mm	4
4	Taper-Lock bush, 1615 × 24mm bore	1
5	Taper-Lock bush, 1615 × 19mm bore	1
6	Pulley, P36, 8M, 30F	2
7	Belt, UniRoyal 960, 8M, 30	1
8	Shaft extension, for feed drive	1
9	Socket head screw, M6 × 6mm	1

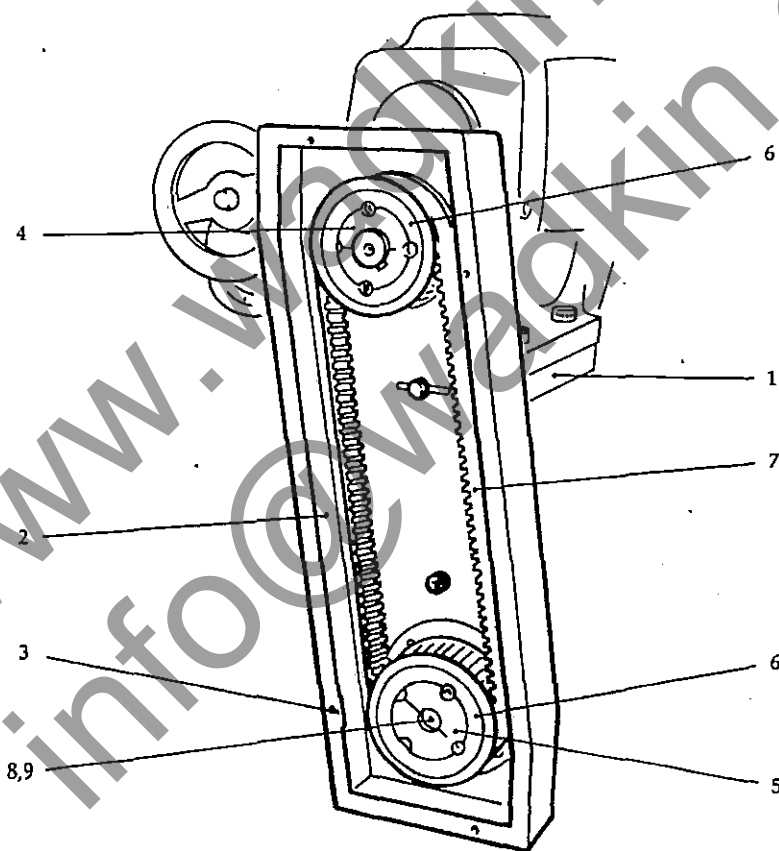

FIG 10—FEED ROLL BELT DRIVE—M/C 109 TO 192 EXCLUDING 147, 148, 172 &amp; 173.

## 11. SINGLE SIDE ROLLER PRESSURE UNIT OPPOSITE FENCE SIDE HEAD

Ref. No.	Description	No. Off
1	Bracket, single roller side pressure unit	1
2	Pin, side pressure roller	1
3	Pressure roller	1
4	Sliding shaft, pressure roller	1
5	Infeed pressure spring	1
6	Hexagon head screw, M12 x 35mm long, for GA128	2
7	Washer 12mm, bright mild steel, for GA128	2
8	'Heyco' nylon domed plug, black, 8mm hole, DP312 for GA128	1
9	Circlip, 20mm external, for GA 110	1
10	Bearing, SKF 6004 2RS, for GA 110	1
11	Tension pin, 8mm dia x 30mm long, for GA111	1
12	Tension pin, 5mm dia x 30mm long, for GA111	1

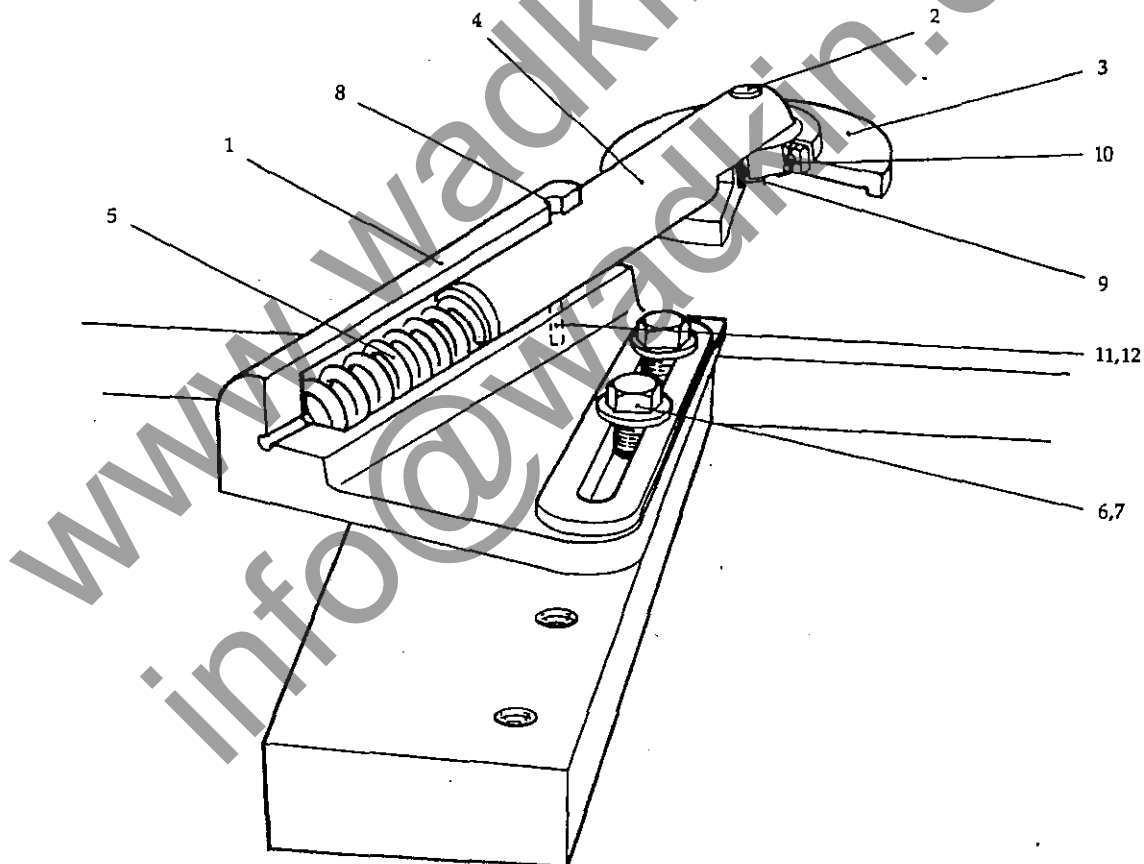

FIG 11 SINGLE SIDE ROLLER PRESSURE UNIT



## 12. TOP ROLLER PRESSURE UNIT

Ref. No.	Description	No. Off
1	Barrel, top pressure roller	1
2	Spring tensioner, top pressure	1
3	Split clamp, top pressure barrel	1
4	Roller arm, top pressure	1
5	Roller, top pressure	1
6	Roller pin, top pressure	1
7	Spring, infeed pressure	1
8	Tension pin, 8mm dia. x 24mm long	1
9	Tension pin, 5mm dia. x 24mm long	1
10	Hexagon head screw, M12 x 45mm long	2
11	Circlip, 20mm external	1
12	Bearing, SKF 6004 2RS	1

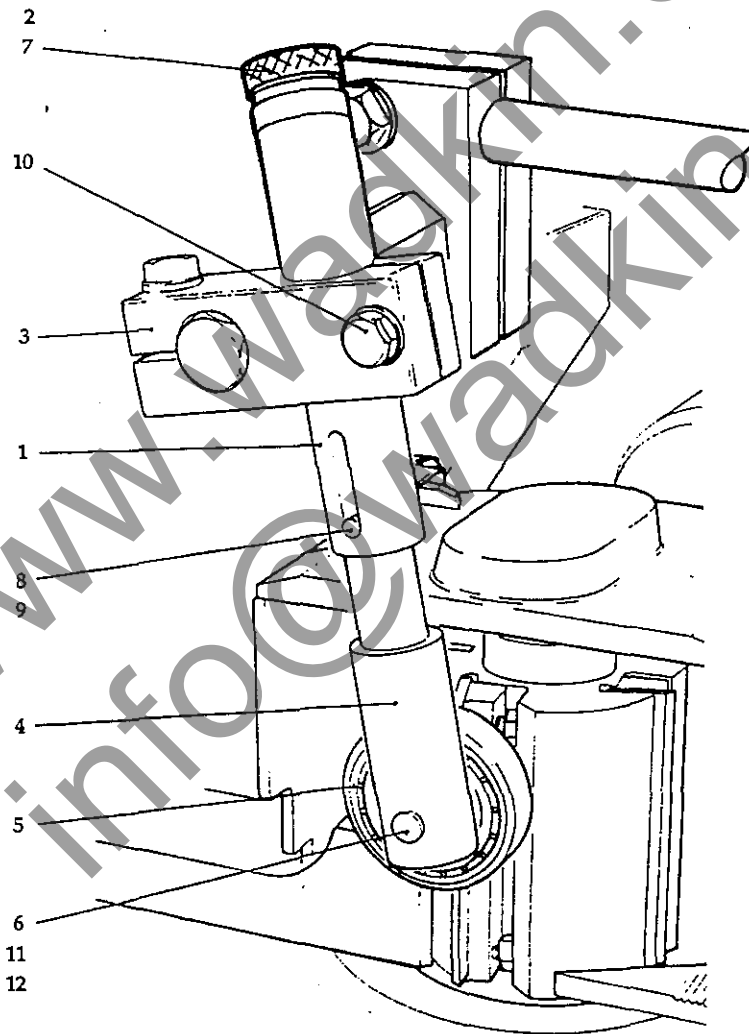

FIG12 TOP ROLLER PRESSURE UNIT

13. BEAM POWER RISE AND FALL

Ref. No.	Description	No. Off
1	Beam support bracket	1
2	Vertical slide	1
3	Nut, beam rise and fall	1
4	Rise and fall screw	1
5	Top cover, wormgear	1
6	Housing, wormgear	1
7	Wormshaft, beam rise and fall	1
8	Wormwheel, beam rise and fall	1
9+	Thrust washer/bearing assembly	1
10	Hex. locknut	2
11	Collar, motor rise and fall	1
12	Collar, rise and fall	1
13	Connecting shaft	1
14	Square end, rise and fall shaft	1
15	Stud, motor support	4

+ not illustrated, refer to Wadkin

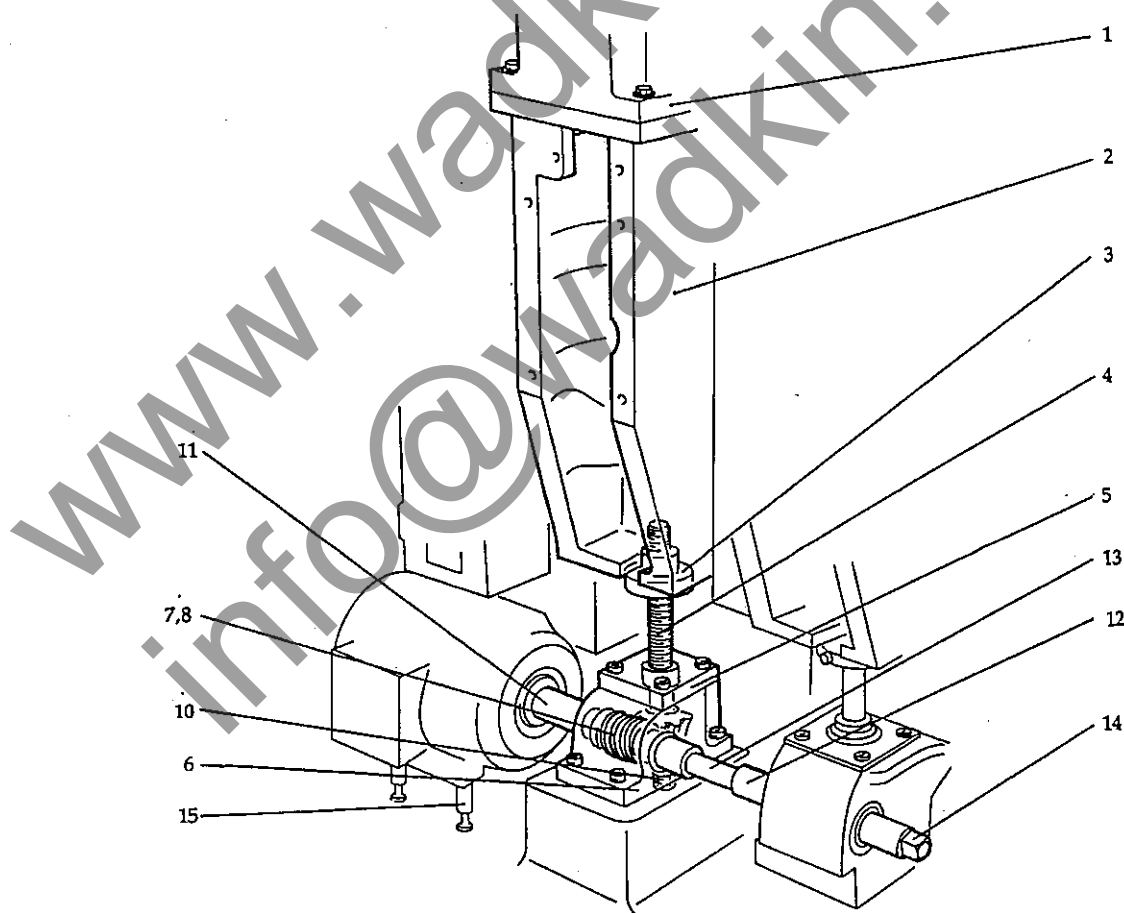

FIG 13 BEAM POWER RISE AND FALL



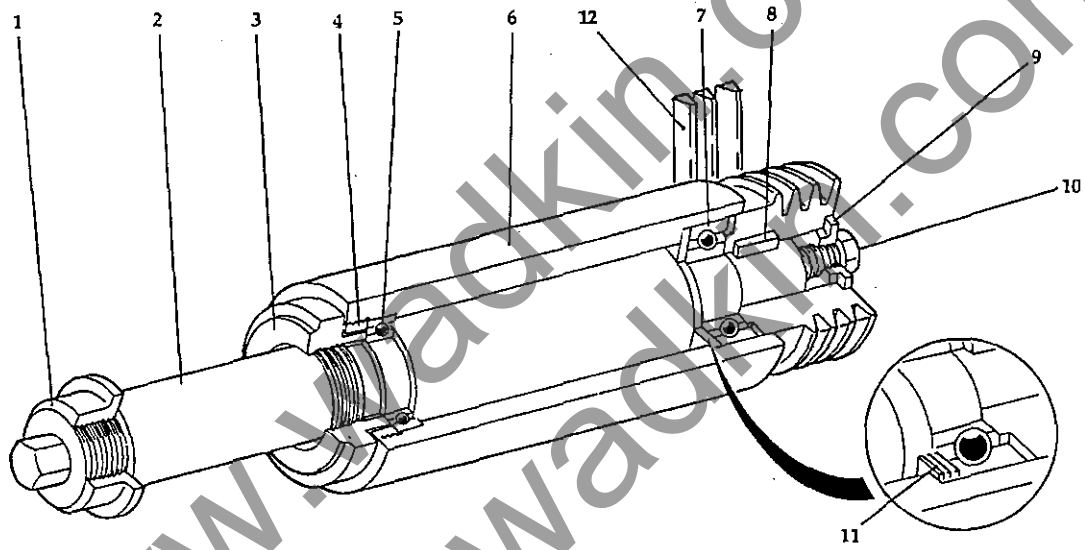

FIG14 ALL SPINDLE UNITS—40MM DIAMETER

## 14. ALL SPINDLE UNITS — 40MM DIAMETER

Ref. No.	Description	No. Off
1	Locking nut	1
2	Spindle, 40mm dia. sq. shoulder	1
3	Bearing nut, Bottom and Near Side head spindles	1
4	Bearing nut, spindle housing	1
** 5	Bearing, RHP or SKF 6009	1
6	Barrel, Bottom and Near Side spindles	1
** 7	Bearing, RHP or SKF 6306	1
8	Parallel key, 8mm x 7mm 40mm long	1
9	Pulley spigot for spindle	1
10	Hexagonal head screw, M12 x 45mm long	1
11	'Belleville' series 'K' disc spring, for bearing 6306, 71.5mm OD x 45.5mm ID x 0.7	6
12	Vee belt (see Drive Belt data)	2 or 3

\*\* 'KLUBER' Grease packed

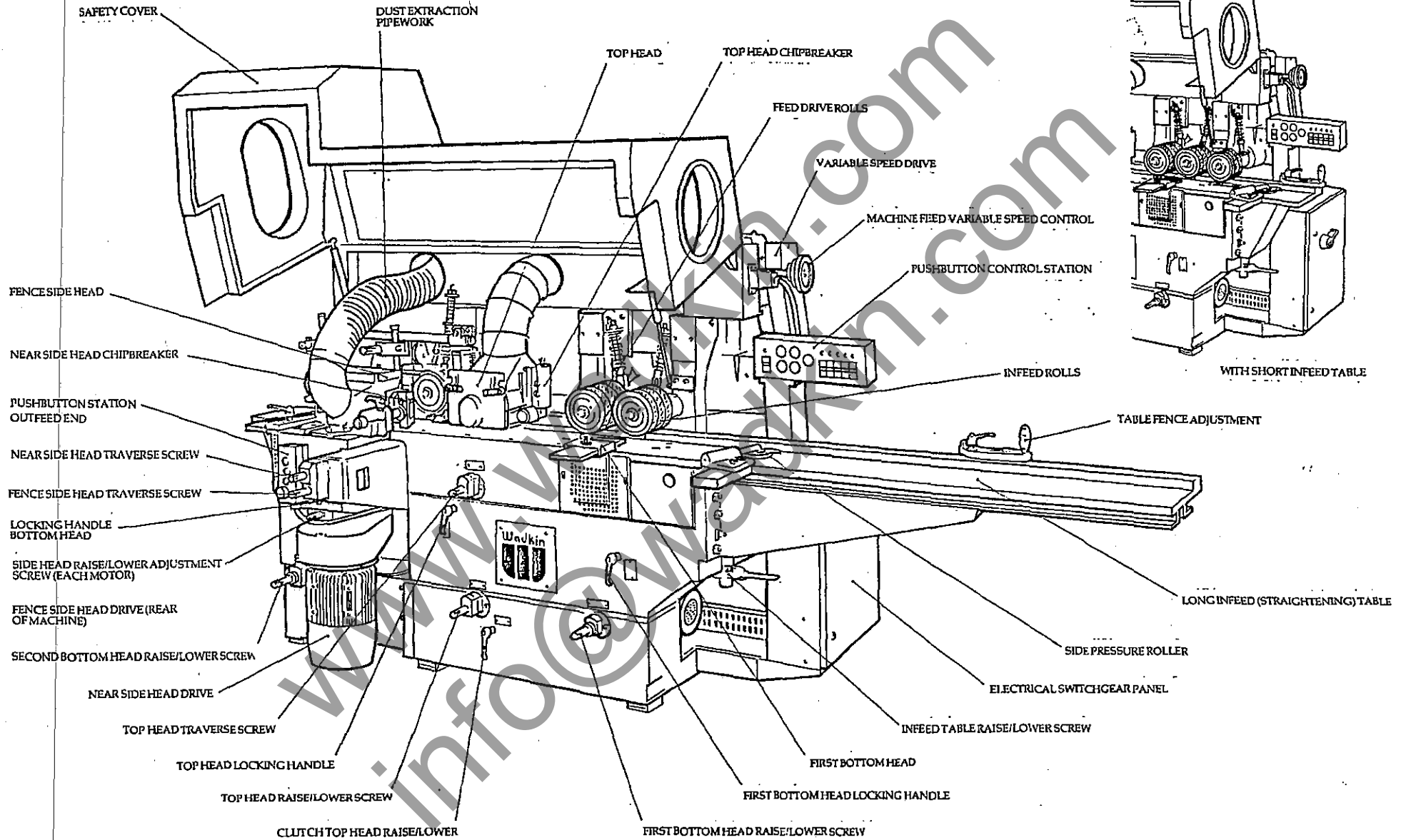

FIG 1 MAIN VIEW OF MACHINE

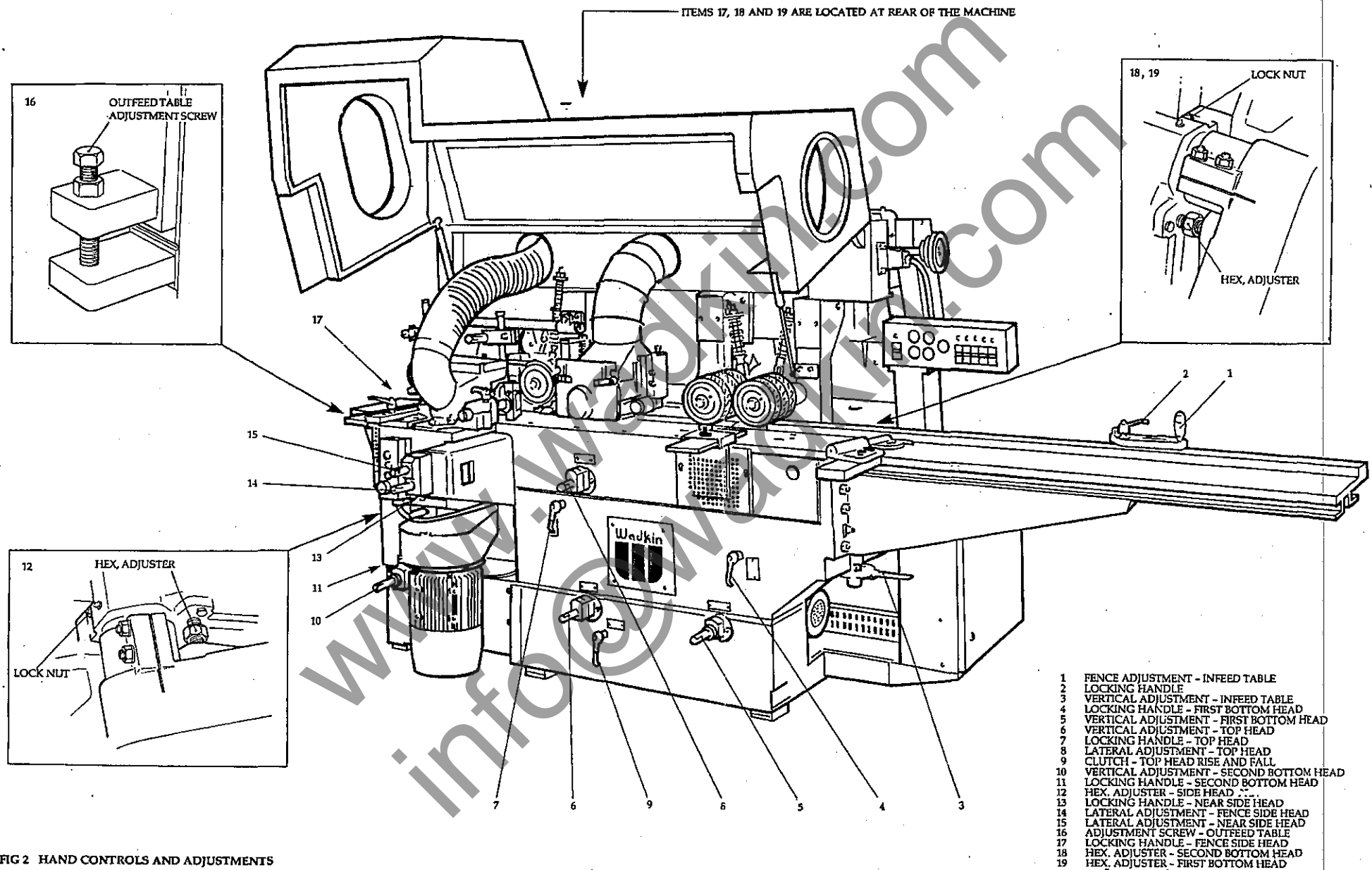

FIG 2 HAND CONTROLS AND ADJUSTMENTS

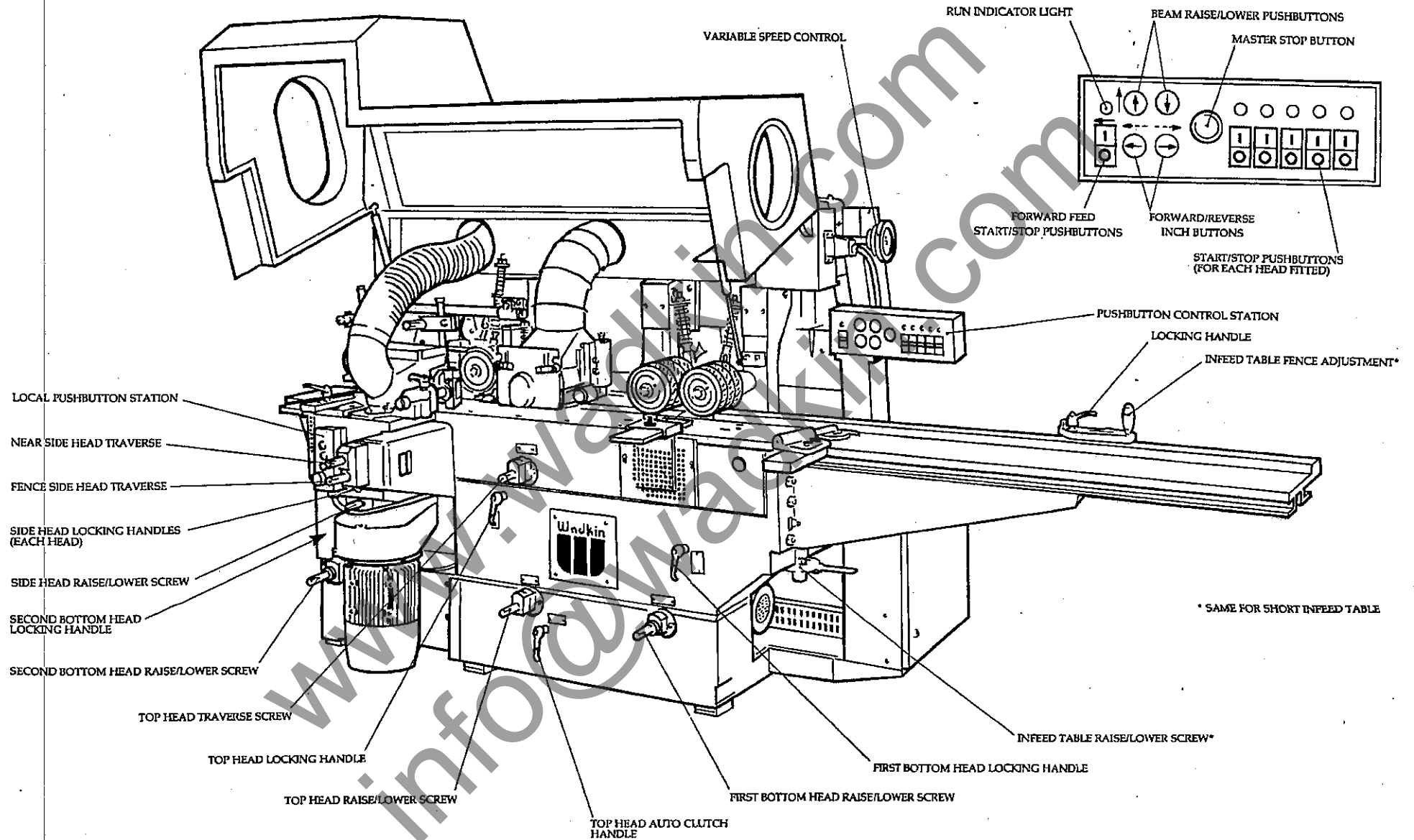

FIG 1 MACHINE CONTROLS